

PIZZERIA Pronto™ OUTDOOR PIZZA OVEN

from the makers of
 pizzacraft®

Makes great tasting,
traditional Italian pizza –
with bubbly cheese, crispy
crust & toasty toppings.

OWNER'S MANUAL

IMPORTANT: This instruction manual contains important information necessary for the proper assembly and safe use of the appliance.

Read and follow all warnings and instructions before assembling and using the appliance. Keep this manual for future reference.



Pizzeria Pronto™
Pizzacraft®
PC6000/ PC6002/ PC6004/ PC6005
CS092413
©The Companion Group 2013
1250 9th Street, Berkeley, CA 94710
1.800.521.0505
info@companion-group.com
CERTIFICATION ETL-Pending



Conforms to ANSI STD Z21.89b-2012
Certified to CSA STD 1.18b-2012
Outdoor cooking specialty gas appliances

UNPACKING INSTRUCTIONS

When unpacking do not disturb starter, doing so could affect starting performance. Position is set at factory.

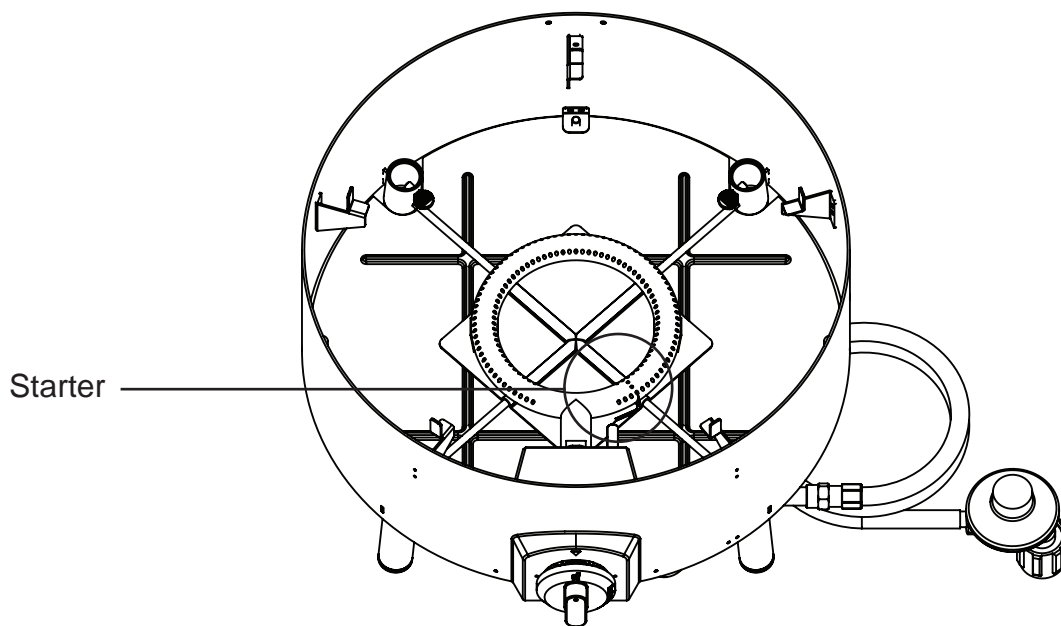

Remove protective silicone caps from stone brackets before use.

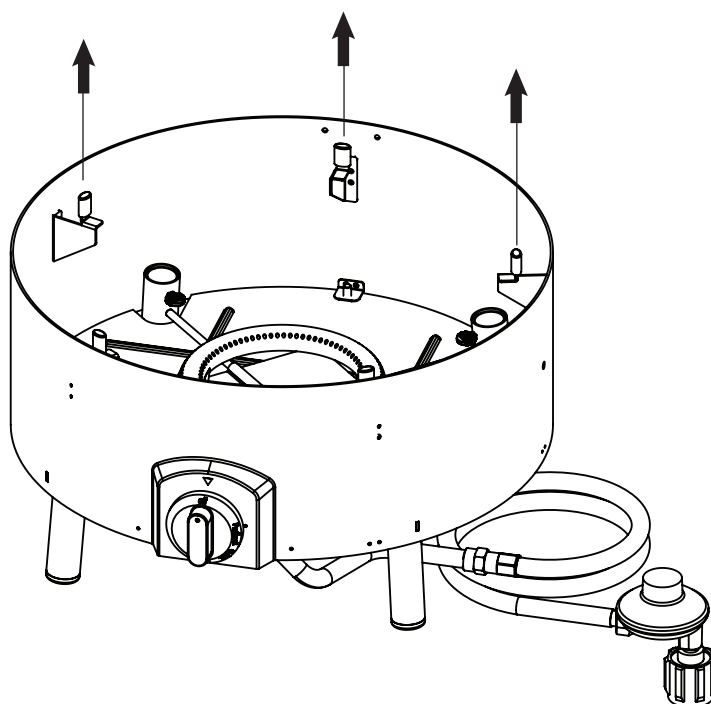

DANGER

If you smell gas:

1. Shut off gas to the appliance.
2. Extinguish any open flame.
3. Remove hood.
4. If odor continues, keep away from the appliance and immediately call your fire department.

Failure to follow these instructions could result in fire or explosion, which could cause property damage, personal injury or death.

DANGER

1. Never operate this appliance unattended.
2. For outdoor use only.
3. Never operate this appliance within 48 inches (122 cm) of any structure, combustible material or other gas cylinder.
4. Never operate this appliance within 25 ft. (7.5 m) of any flammable liquid.
5. If a fire should occur, keep away from the appliance and immediately call your fire department. Do not attempt to extinguish an oil or grease fire with water.

Failure to follow these instructions could result in fire or explosion, which could cause property damage, personal injury or death.

CALIFORNIA PROPOSITION 65 WARNING:

The burning of gas cooking fuel generates some by products, which are on the list of substances known by the State of California to cause cancer, reproductive harm, or other birth defects. This product may contain chemicals known to the state of California to cause cancer, reproductive harm, or birth defects. To reduce exposure to these substances, always operate this unit according to the use and care manual, ensuring you provide good ventilation when cooking with gas.

TABLE OF CONTENTS

Safety Information	5
Assembly Instructions	6
Installation Instructions	9
Operation Instructions	12
Care and Maintenance.....	15
Troubleshooting.....	17
Accessories	18
Replacement Parts	19
Warranty and Registration	20

SAFETY INFORMATION

1. Installation of this appliance must conform with local codes, or in the absence of local codes, with the National Fuel Gas Code, ANSI Z223.1/NFPA 54, Storage and Handling of Liquefied Petroleum Gases, ANSI/NFPA 58; or Natural Gas and Propane Installation Code, CSA B149.1; Propane Storage and Handling, CSA B149.2; or the Standard for Recreational Vehicles, ANSI A119.2/NFPA 1192; and Recreational Vehicle Code, CSA Z240 RV Series, as applicable.
2. This appliance shall be used only outdoors, and shall not be used in a building, garage or any other enclosed area. Keep the oven away from windy areas but keep the oven in a well-ventilated area. Do not obstruct the flow of combustion and ventilation air around the oven.
3. This appliance should not be installed in or on a boat or on recreational vehicles.
4. Keep appliance area clear and free from combustible materials, gasoline and other flammable vapors and liquids. A minimum clearance of 48 inches (122 cm) from combustible constructions must be maintained. This outdoor cooking gas appliance must not be placed under overhead combustible construction.
5. Inspect the hoses before each use for excessive abrasion or wear, or cuts that may affect safe operation of the oven. If there is evidence of excessive abrasion or wear, or the hose is cut, it must be replaced prior to the oven being put into operation. The replacement hose assembly must be specified by the manufacturer, by calling 1-800-521-0505.
6. Keep the fuel supply hose away from any heated surface(s). Hose should not be routed under oven.
7. The use of alcohol, prescription or non-prescription drugs may impair the consumer's ability to properly assemble or safely operate the appliance.
8. When cooking, the appliance must be on a level surface in an area clear of combustible material.
9. Do not leave the appliance unattended. Keep children and pets away from the appliance at all times.
10. This appliance is not intended for commercial use.
11. Use caution when placing anything into oven while the appliance is in operation.
12. Do not move the appliance when in use. Allow the oven to cool to 115°F (45°C) before moving or storing.
13. This appliance is not intended for and should never be used as a heater.
14. This appliance will be hot during and after use. Use insulated oven mitts or gloves for protection from hot surfaces.
15. This oven is equipped with a flame observation hole on the right side of the oven body. Wear protective eye wear to look through hole as it will be very hot and could burn you. Do not get too close.
16. Oven should be protected from windy areas during use.
17. The hood should not be removed during cooking or while oven is hot.

Specification

Product weight: 25 lbs

Assembled Dimensions: 38.5 mm x 42 mm x 45.5 mm

Heat output: 14,500 Btu's

ASSEMBLY INSTRUCTIONS

Before beginning assembly of product, make sure all parts are present. Compare parts with package contents and hardware contents list. Do not discard packing materials before assembly is complete. If any part is missing or damaged, do not attempt to assemble the product. Call customer service at 800-521-0505.

To watch assembly video go to companion-group.com/pizzeria-pronto/assembly.html

Estimated assembly time: 20 minutes

Tools required- #2 Phillips screwdriver, not included.

PACKAGE CONTENTS:

1. Rain cover
2. Hood
3. Baking stone (2 parts)
4. Oven body
5. Knob
6. Hardware package
7. Gas inlet assembly
8. Legs (4)

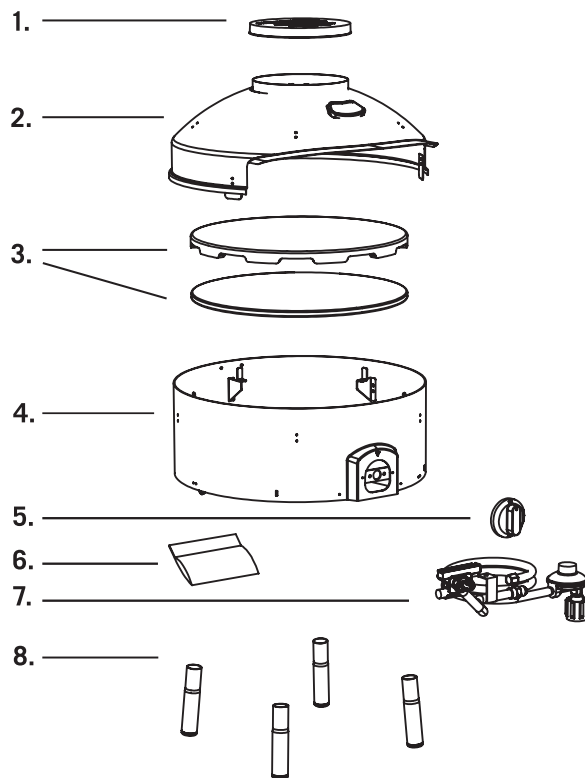

HARDWARE PACKAGE CONTENTS:

1. (4) M4x8 Phillips screws - for legs
2. (3) M3x5 Phillips screws - for gas inlet assembly



1. Attach legs to body as shown; secure with M4x8 Phillips screws. Tighten by hand, level oven as needed.

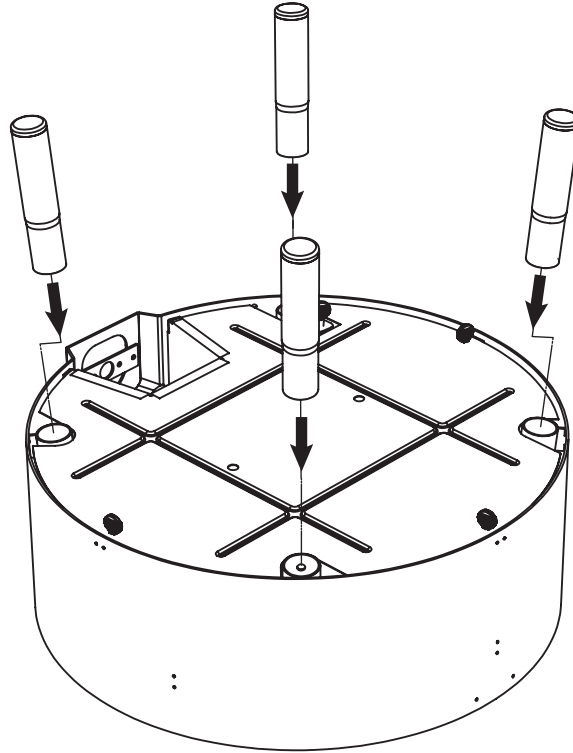

2. Insert gas inlet assembly into body as shown. Secure control valve with 2 supplied screws to body front then secure pipe support with the third M3x5 Phillips screw. Attach control knob by aligning the keyway and pushing onto valve spindle. Connect starter wire from valve assembly to starter plug by firmly pushing it into place.

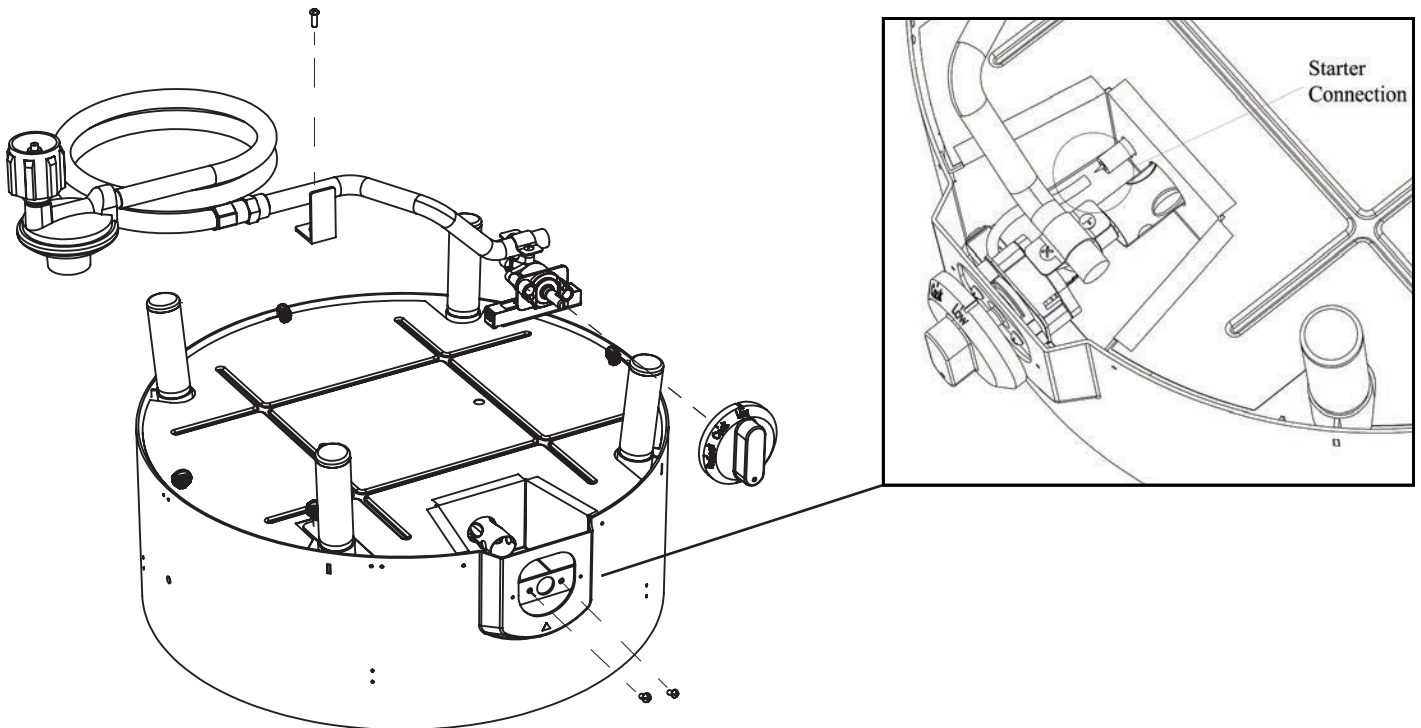

3. Place the oven on a sturdy, level, heat-resistant surface on which you will be cooking. Place the two baking stones as shown into oven so they rest on the support brackets. The flat stone belongs on the bottom; the stone with indentations should be placed on top as shown below. *Note the stones are fragile; use care in handling and placing the stones.*

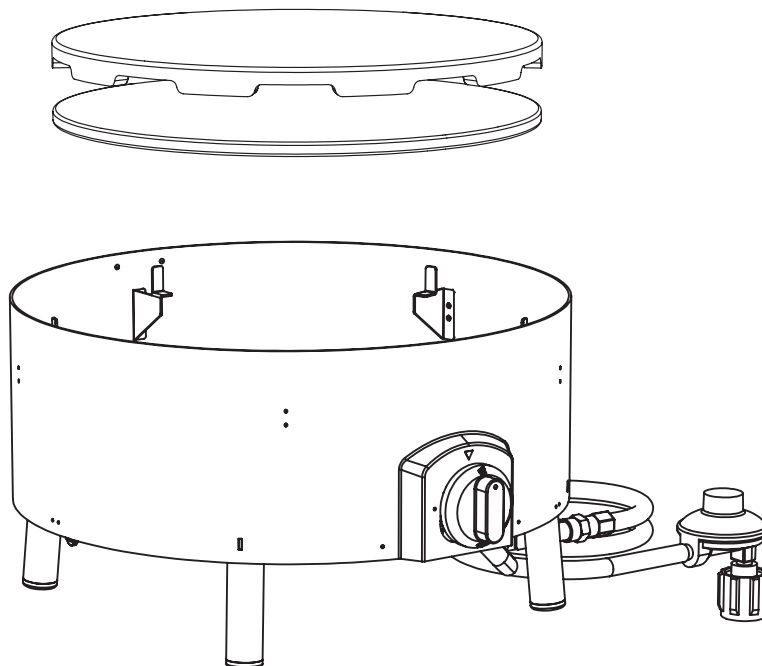

4. Place the hood with the rear-aligning tab contacting first. Then set down the cover so the cover rim overlaps the oven body.

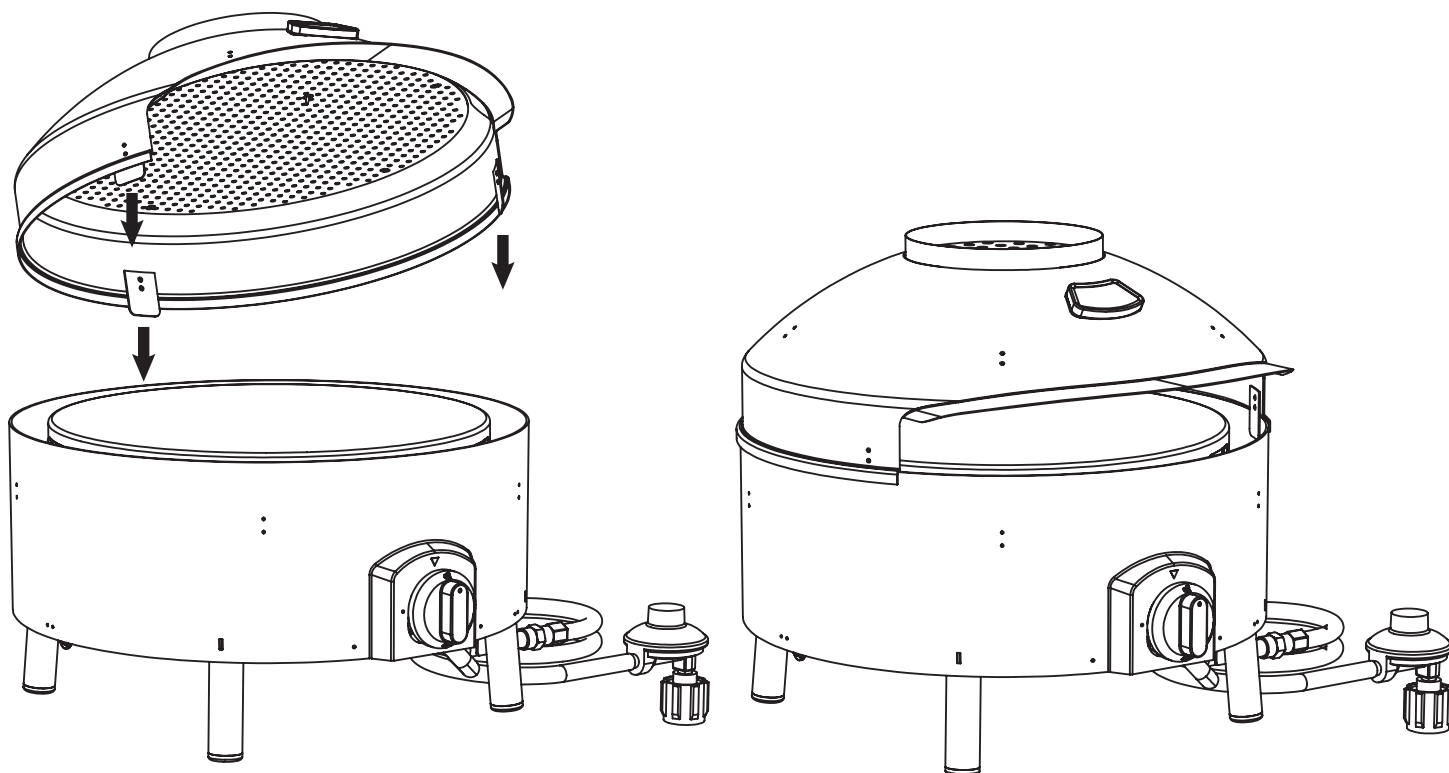

INSTALLATION INSTRUCTIONS

For Portable Liquid Propane -Gas Connection

Gas Requirements:

The oven is set and tested at the factory for use with LP gas only.

⚠ WARNING

Do not attempt to operate your oven on other gases. Failure to follow this warning could lead to a fire hazard and bodily harm. Doing so will void your warranty.

⚠ WARNING

The Type 1 connective coupling supplied with your oven must not be replaced with a different type of oven/tank connection system. Removal could result in loss of warranty, gas leakage, fire, and severe bodily harm. Doing so will void your warranty.

The propane tank valve connection supplied with this oven incorporates four important safeguards: Hand Assembly, Hand Disassembly, Excess Flow Control, and Temperature- Activated Shut-Off.

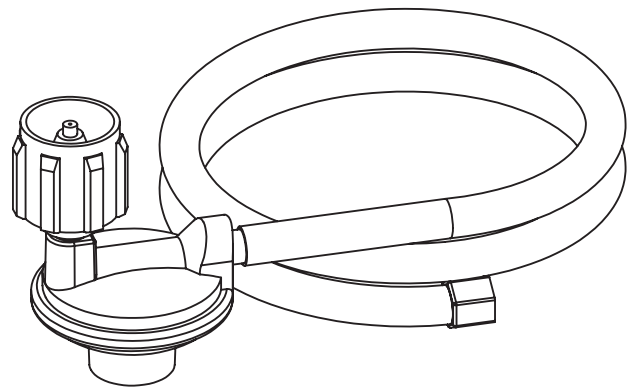

A. HAND ASSEMBLY

1. Make certain the tank valve and all the appliance valves are in the “OFF” position.
2. When connecting the regulator/burner valve assembly to the tank valve, turn the large plastic nut clockwise until it stops.
3. Gas will not flow unless the plastic nut is completely connected.
4. HAND TIGHTEN ONLY.

B. HAND DISASSEMBLY

1. Make certain the tank valve and all the appliance valves are in the “OFF” position.
2. Turn the large plastic nut counter-clockwise until it is disassembled.
3. HAND LOOSEN ONLY.

C. EXCESS FLOW CONTROL

The propane regulator assembly incorporates an excess flow device designed to supply the oven with sufficient gas flow under normal conditions yet control excess gas flow. Rapid changes in pressure can trigger the excess flow device providing a low flame and low temperature. If the tank valve is turned open to allow gas flow while a burner valve is open, the surge of pressure will cause the device to activate. The device will remain closed until the pressure is equalized.

This should occur within 5 seconds. To ensure this does not cause difficulty in lighting the oven, follow these instructions:

1. Make sure the burner valve is “OFF”.
2. Open the tank valve and wait 5 seconds.

D. TEMPERATURE-ACTIVATED SHUT-OFF

The large plastic nut on the regulator assembly is designed in coordination with a check valve in the tank valve to shut off the flow of gas when exposed to temperatures between 240°-300° F (115°-148° C). In the event of a fire or hose break, one of the safeguards will function to control or stop the flow of gas from the propane tank. Never attempt to use damaged equipment.

Checking for Gas Leaks

Before operating your oven or after refueling, check carefully to be certain that all connections are tight and there are no gas leaks.

1. Make 3 oz. of leak solution by mixing liquid dish washing soap with water.
2. Make certain the control knob is in the “OFF” position on the oven.
3. Brush small amounts of the leak solution on all the fittings and turn the gas on at the tank.
4. If bubbles appear, there is a leak. Proceed to step 5.
5. Turn the gas off at the tank and tighten connections.
6. Go back to step 1 to retest the fittings.
7. If bubbles continue to appear, turn the gas off at the tank. Contact customer service.

Liquid Propane (LP) Tank Safety Information

1. Up to 20 lb. gas cylinder can be used with the oven. The cylinder must be constructed and marked in accordance with the Specifications for LP Gas Cylinders of the U.S. Department of Transportation (D.O.T.) or the National Standard of Canada, CAN/CSAB339, Cylinders, Spheres, and Tubes for Transportation of Dangerous Goods; and Commission. Storing the appliance indoors is permissible only if the cylinder is disconnected and removed from the appliance.
2. DO NOT obstruct the flow of combustion and ventilation air to this appliance.
3. Never use the oven without the crumb tray installed under the burner area. Without the crumb tray, hot debris could leak downward and produce a fire hazard.
4. Do not store a spare LP-gas cylinder under or near this appliance.
5. Never fill the cylinder beyond 80% full.



WARNING

Make certain your LP (propane) tank is filled by a reputable propane dealer. An incorrectly filled or an overfilled LP tank can be dangerous. The overfilled condition combined with the warning of the LP tank (a hot summer day, tank left in the sun, etc.) can cause LP gas to be released by the pressure relief valve on the tank since the temperature increase causes the propane to expand. LP gas released from the tank is flammable and can be explosive.

The tank supply system must be arranged for vapor withdrawal.

The tank used must include a collar to protect the cylinder valve.

Do not store the tanks (whether full or empty) inside your home, the living area of an R.V., a garage, basement, or in reach of children or pets. It is unlikely that liquid propane will leak from the tanks. If it should leak, the fuel could be exposed to sparks from automobiles, power tools, or other appliances. When storing or transporting your LP tank, it must remain in an upright position. Never lay your LP tank down on its side whether it is full or empty. Never store a spare tank under or near your gas appliance.

CAUTION

Never transport or move your oven or oven tank without first closing the manual valve on your LP (liquid propane) gas tank.

Gauging Amount Of LP (liquid propane) Fuel In Tank

To gauge the amount of propane fuel in your gas tank, the oven must be in operation with the tank connected. Using caution not to get too close to the oven, place your hand at the top of the tank and slowly move down the side until the tank feels cool to the touch. This will indicate the approximate amount of propane gas in your tank; if $\frac{3}{4}$ empty, refill.

WARNING

Do not use charcoal briquettes or any other flammable material with your oven. Use of such material will void your warranty and may lead to a fire, explosion, and bodily harm.

WARNING

Never use a match or open flame for leak detection. Use of an open flame could result in a fire, explosion, and bodily harm.

IMPORTANT: Before using a fresh tank of gas check leakage around the connections according to section “Checking Gas Leaks” above and make sure there is no leakage.

IMPORTANT: Place dust cap on cylinder valve outlet whenever cylinder is not in use. Only install the type of dust cap on the cylinder valve outlet that is provided with the cylinder valve. Other types of caps or plugs may result in leakage of propane.

OPERATING INSTRUCTIONS

BREAKING IN YOUR OVEN

When firing your oven for the first time, it is advisable to run the burner on “High” for 20 minutes and then turn the oven off and let cool to room temperature. This tempers the oven and once cool is ready for use. *Note that each burner has been tested before it left the factory, discoloration of the metal is a natural result of the material being heated.*

OVEN LIGHTING INSTRUCTIONS

To Light the Burner:

1. Make sure the control knob is in the “OFF” position.
2. Make sure chimney vent in the hood is unobstructed and rain cover is removed.
3. Open the LP (liquid propane) Gas tank valve.
4. Push the control knob in and turn to the left to “High” position.
5. If the burner does not ignite within 5 seconds, immediately turn control knob back to “OFF” position. Wait 5 minutes and repeat step 3 two or three times.
6. If the burner still does not ignite, TURN OFF THE GAS. WAIT 5 MINUTES for excess gas to dissipate.
7. If the burner still can't be lit, refer to the Troubleshooting section.
8. If the burner flame is accidentally extinguished during cooking repeat steps 1-7.
9. Keep the tank valve closed when not in use.

ABOUT COOKING PIZZA

Pizzeria Pronto™ is designed to provide an authentic pizza experience that wasn't possible before with a barbecue grill or kitchen oven. Pizzeria Pronto™ fires to 700°F or more for an ambient temperature that quickly cooks the top of the pizza while the lower stone temperature carefully crisps the crust.

This balance can be greatly effected by the type of pizzas you are cooking (crust thickness, amount of topping) and the weather conditions (outside temperature and wind). Don't worry if it takes a few pizzas to get your technique perfected. After all, Rome wasn't built in a day!

PREHEATING OVEN

It is extremely important that your oven reach the ideal baking temperature before you begin using it. After lighting, run the oven on “High” for 10 minutes, but no more than 15 minutes. This preheating will ensure that the internal oven and stone temperatures are hot enough for proper baking.

COOKING PIZZA

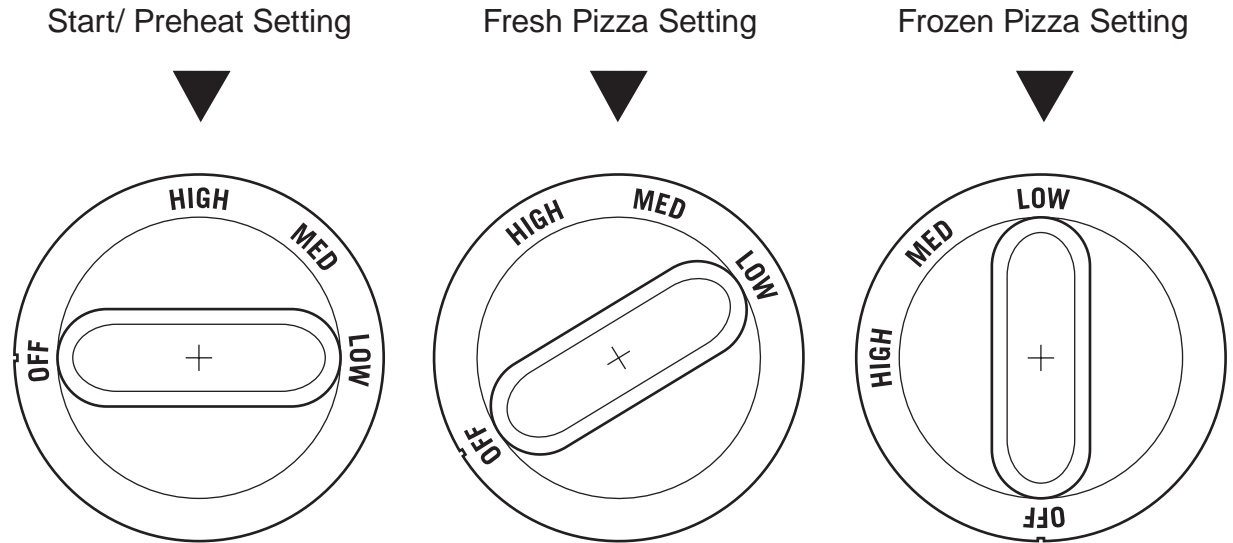

FRESH PIZZA

If cooking a fresh pizza with raw pizza dough turn the control knob slightly between “Med” and “High” depending on the weather. Using a peel, place the pizza in the center of the oven.

Expect the pizza to cook in 5 minutes. The pizza should be turned 180 degrees halfway through for even cooking. Once cheese is melted and the outer crust and underside has browned your pizza is done and the oven is ready for the next pizza.

Tips

- Dust the pizza peel with plenty of flour, or corn meal to prevent sticking. Don't let a fresh, uncooked pizza sit on the peel for longer than five minutes, as it will stick.
 - An aluminum peel prevents sticking best and is recommended by the manufacturer.
 - Check the underside of the pizza 2-3 minutes after it is in the oven to make sure the stone isn't getting too hot. If so, turn the temperature down slightly.
 - The thicker the crust, the lower you will want to set the oven temperature.
 - Dough will be much easier to work with if it's at room temperature. Leave it out covered at few hours before cooking.
 - When sliding in the raw pizza aim for the center
- of the stone. It is possible to push the pizza off the back of the stone- take care to center your pizza. If you need to move the pizza, wait approximately 30 seconds while the dough sets, then move the pizza to center.
- Protect the oven from wind. Strong wind can cause the internal temperature to drop. The thermometer needs to stay about 600°F to make perfect pizzas.
 - Once a pizza is finished cooking, the oven immediately is ready for another one. Pizzeria Pronto™ performs best when pizza are cooked successively. Do not allow the oven to run empty longer than 15 minutes between pizzas as this can also allow the stone to overheat.
 - For camping and tailgating consider using a 1 lb. disposable propane bottle that typically lasts 2 hours of use.
 - Oven temperature will vary with the outside temperature. The oven temperature may need to be hotter on a cold day or cooler on a hot day, as with any oven or grill.

PIZZACRAFT® DOUGH RECIPE

Ingredients

- 3 cups pizzacraft® “00” pizza flour
- ½ teaspoon active yeast
- 1 ½ teaspoons kosher salt
- 1 ½ cup water

Combine all ingredients in a mixing bowl and stir to form a rough, shaggy dough. Use more water if dough is overly dry and more flour if it seems very wet. Before kneading, allow rough dough to rest for 10 minutes so that the water has time to absorb. Knead dough in a stand mixer for 6-7 minutes or 10-12 minutes by hand until smooth and elastic. Place the dough in a clean bowl and let it rise for 2 hours or until doubled in size. Punch dough to release gas and divide into 2 or 3 pieces. Shape dough into balls and place onto a floured mat, cover with plastic wrap and let rise again for approximately one hour. After the second rise, the dough is ready to be shaped into a pizza and topped with your favorite ingredients.

Note: If time allows, let dough rise in the refrigerator for at least 24 hours. A slow rise in the refrigerator will produce more flavorful dough. When you are ready to use, remove from the refrigerator and shape into 2 or 3 smaller dough balls. Place onto a floured mat, cover with plastic wrap and let rise again for approximately two hours or until it feels warm to the touch. Shape and top as desired.

Store pizzacraft® “00” flour in an airtight container to preserve freshness.

PAR-BAKED AND FROZEN PIZZA

For frozen pizza or pizza purchased from a restaurant that was partially baked, set the control knob to “Low”. Set the pizza in the center of the stone. A much lower heat is required to finish cooking this type of pizza. Follow the pizza manufacturing instructions.

Tips

- Using a pizza screen helps keep the underside from cooking too quickly.
- Less flour or corn meal is needed as frozen pizzas stick far less than fresh.
- You can still add your own toppings to your frozen crust to customize it.

CARE AND MAINTENANCE

CLEANING

Porcelain Coated Steel Finish

The outside of this oven is made of high heat rated porcelain coated steel. To clean, wipe the outside surfaces with a cloth dampened with water and a mild dish washing detergent; dry immediately. Do not use abrasive scrubbers or the finish may become scratched or damaged. Never clean the oven when it is hot. The manufacturer recommends cleaning the exterior of the oven twice yearly or as needed.

Cordierite Baking Stone

To keep the baking stones free of charred food remains, run the oven on “High” for 10 minutes after cooking is complete and pizza has been removed. Most food particles that remain on the stone will burn off due to the high heat inside the oven. If necessary, the stone may be removed from the oven occasionally for a more thorough cleaning. Only when the oven and baking stone have completely cooled, remove the hood to reveal the stone. Run it under hot water while scrubbing with a brush. Natural stiff bristled brushes are recommended by the manufacturer. Do not use soap on the stones as it may leave a soapy aftertaste. The natural properties of the baking stone will cause it to darken and spot with age – do not attempt to remove this discoloration. Air-dry the stone and store inside the oven. The manufacturer recommends cleaning the baking stone after each use.

Crumb Tray

Particles of food are caught in the crumb tray directly below the oven. Only once the oven has cooled, use a long handled brush or shop vacuum to clear out burnt particles. The tray can also be removed with the cover and stone in place by unscrewing the three thumb screws and lower the tray. Clean with mild soap and water. The manufacturer recommends cleaning the crumb tray after each use.

Burner Tube

Visually check the burner flames prior to each use. The flames should be blue. If they are not, clean

burner tubes for insects and nests. A clogged tube can lead to a fire beneath the oven.

Storage

Once cooled and cleaned the oven can be stored outside with the rain cover in place or with an optional fabric cover. We recommend disconnecting the gas tank before storing inside.

WARNING

The baking stones must be completely cooled before handling. The stones can hold high temperatures long after the oven has been turned off. Please use extreme caution when handling to avoid severe burns. Baking stones should be air dried completely before use. Failure to do so may result in damage to the stone.

WARNING

Do not cover the oven while it is in use or still hot. Oven and all parts must be completely cooled before covering to avoid damage to oven, or creating a fire hazard which may result in property damage or injury.

WARNING









Please remember this is an outdoor gas oven. Many areas of the oven generate extreme heat. We have taken every precaution to protect you from the contact areas. However, it is impossible to isolate all high-temperature areas. Therefore, use good judgment and a certain degree of caution when using this product. We suggest covered, protected hands during operation of oven. Do not move your oven when it is in operation or hot to the touch. Wait until your unit is turned off and properly cooled down before moving it. Failure to follow this warning could result in personal injury.

TROUBLESHOOTING

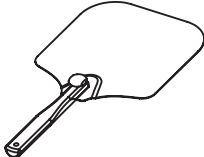
PROBLEM	CAUSE	SOLUTION
Burner will not light	Low fuel	Replace tank
	Starter mechanism damaged	Replace
	Safety mechanism trip	Follow reset instructions
Bottom of pizza burning	Stone too hot	Turn down burner, wait 5 minutes
		Use metal screen under pizza
		Precook toppings
Bottom not cooking quickly	Stone too cold	Preheat longer
Oven not hot enough	Wind pulls heat from the oven	Protect from the wind
Oven too hot	Too much flame	Turn down the burner
Excessive smoke coming from oven	Crumb tray needs to be cleaned	Let cool, clean tray
Yellow flame	Venturi clogged	Clean burner tube
Burner self extinguishes	Low fuel	Replace tank
	Supply line damaged or leaking	Replace line

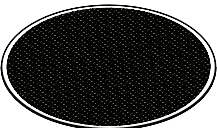
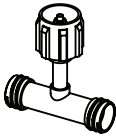
ACCESSORIES

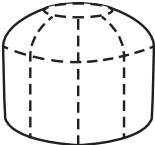
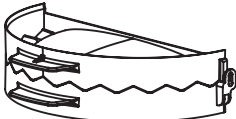
Available at pizzacraft.com/accessories.html

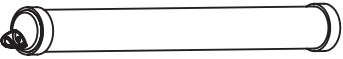
ACCESSORY	DESCRIPTION	ITEM NUMBER
	1 Pound Disposable Tank Adapter: Allows small portable propane bottle to be used with the pizza oven. Great for tailgating and camping.	PM6013
	Stone Brush: Long handle brush with natural fiber bristles. Keeps stone clean between pizzas.	PM0218
	Folding Pizza Peel: Aluminum peel sized perfect for pizza oven and storage.	PM0216
	Infrared Thermometer: Accurately reads stone surface temperatures. 32°-800° F range.	PM0413
	Pizza Screen: Aluminum screen helps even cooking for frozen pizzas.	PM0306
	Tee Valve: Allows you to use only one or two cooking units for a 20 lb. portable propane tank.	PM6014
	Stone Replacement Set: Designed specifically for the oven to ensure even heat and a crisp crust. (identical to original stone set)	PM6015
	Deluxe Rain Cover: Nylon rain cover offers additional protection for outdoor storage.	PM6012
	Calzone Press: Easy to craft calzones, pastries and more.	Large PM0406 Small PM0405
	Flexible Dough Rolling Mat: Easy to measure and roll perfectly sized pizza crust.	PM0408
	Rolling Pin: Easy to roll out pizza dough.	PM0412

REPLACEMENT PARTS

PARTS

- | | | |
|----------------|-------------------|------------------------|
| 1. Rain cover | 6. Body | 11. Hardware package |
| 2. Thermometer | 7. Gas valve | 12. Crumb tray |
| 3. Hood | 8. Knob | 13. Hose and regulator |
| 4. Stone | 9. Gas inlet pipe | |
| 5. Burner | 10. Legs | |

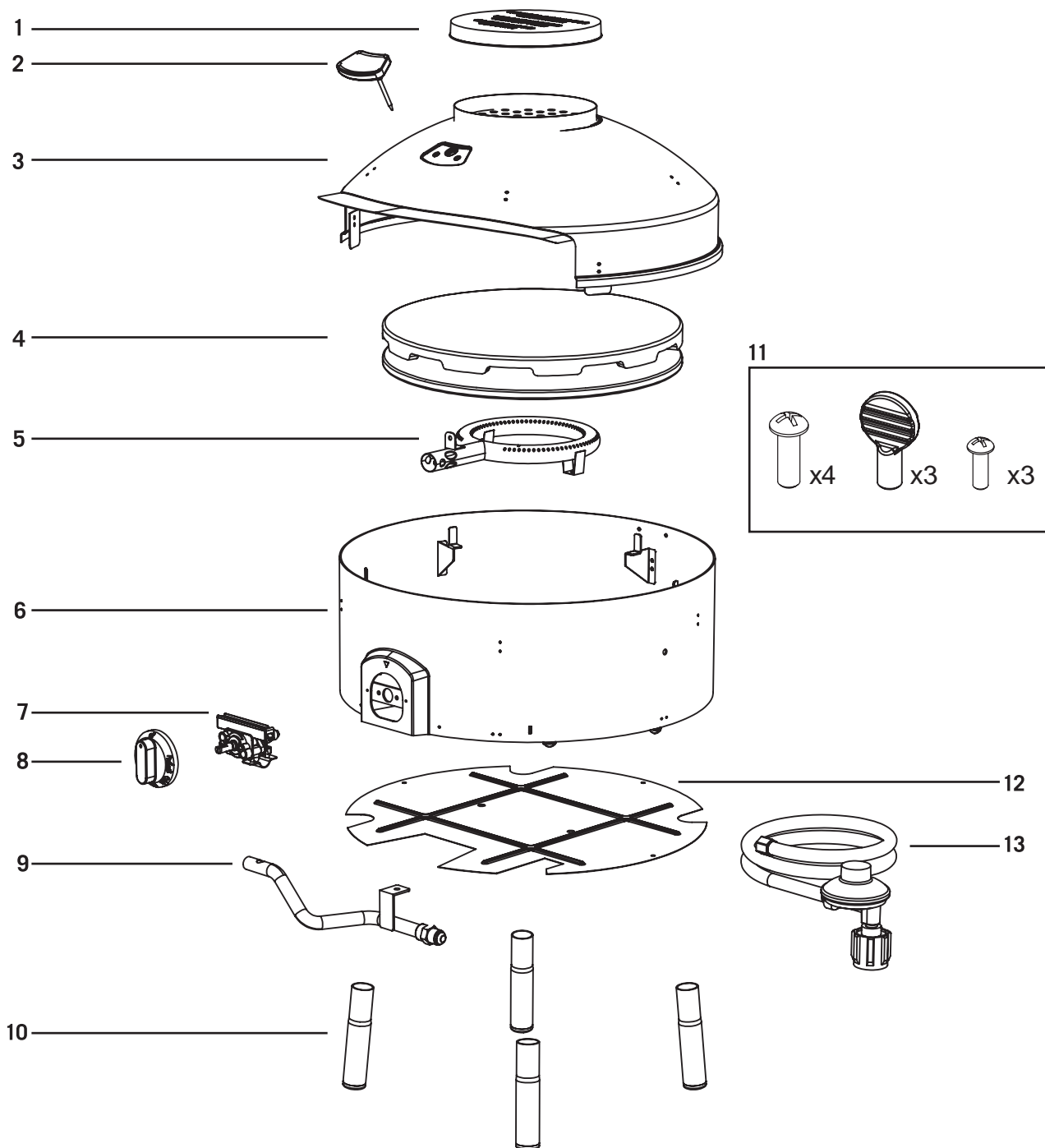

WARRANTY AND REGISTRATION

We guarantee our products for one year from date of purchase for defects in manufacture or materials. We will repair or replace at our option. Proof of purchase is required.

For replacement parts call 1.800.521.0505

**Please register your oven at
pizzacraft.com/register-pizza-oven.html
or with enclosed postcard**