

Cuisinart® INSTRUCTION AND RECIPE BOOKLET



Cuisinart® Elemental™ 13-Cup Food Processor with Dicing Kit

FP-13D Series

For your safety and continued enjoyment of this product, always read the instruction book carefully before using.

RECOMMENDED MAXIMUM WORK BOWL CAPACITY

FOOD	CAPACITY
Sliced or shredded fruit, vegetable or cheese	13 cups
Chopped fruit, vegetable or cheese	6 cups
Puréed fruit or vegetable	6 cups cooked
Chopped or puréed meat, fish or seafood	2 pounds
Thin liquid (e.g., dressings, soups, etc.)	8 cups
Cake batter	8-inch cheesecake batter; 1 box (15.25 ounce) cake mix
Cookie dough	5 dozen (based on average chocolate chip cookie recipe)
White bread/pizza dough	4 cups (all-purpose or bread flour)
Nuts for nut butter	4 cups

RECOMMENDED SMALL WORK BOWL CAPACITY

FOOD	CAPACITY
Chopped fruit, vegetable or cheese	2 cups
Puréed fruit or vegetable	2 cups
Thin liquid (e.g., dressings, soups, etc.)	2 cups
Nuts for nut butter	1 cup

IMPORTANT UNPACKING INSTRUCTIONS

This package contains a Cuisinart® Elemental™ 13-Cup Food Processor and accessories:

Large 13-cup work bowl, small 4.5-cup work bowl, work bowl cover with multiple feed tubes with interlock, flat work bowl cover, accessory storage case, dicing kit and instruction/recipe book.

CAUTION: THE CUTTING TOOLS HAVE VERY SHARP EDGES.

To avoid injury when unpacking the parts, please follow these instructions.

1. Place the box on a low table or on the floor next to the kitchen counter where you intend to keep the food processor. Be sure the box is right side up.
2. Open top flaps – there will be a rectangular block of packing material that holds the processor parts, each fitted into a cavity.
3. Remove the instruction/recipe book.
4. Lift out the packing material.
5. Remove the base, the 13- and 4.5-cup work bowls, and place it on the counter or table. Assemble the work bowls on the base by placing them over the shaft, using the handle to turn the work bowl clockwise to lock it.

6. Always read the Assembly Instructions thoroughly before using your food processor.
7. When ready to use your machine, unlock the accessory storage case, lift the cover and remove the clamshell to access the small metal chopping/mixing blade, dough blade, large metal chopping/mixing blade, stem adapter, adjustable slicing disc, and reversible shredding disc. Each is in a cavity. CAREFULLY REMOVE THE METAL CHOPPING/MIXING BLADE BY GRASPING THE CENTER HUB AND LIFTING IT STRAIGHT UP. NEVER TOUCH THE BLADES, AS THEY ARE RAZOR SHARP. CAREFULLY REMOVE THE ADJUSTABLE SLICING DISC/SHREDDING DISC BY USING THE PLASTIC HUB. DO NOT TOUCH THE BLADES, THEY ARE VERY SHARP. Remember to lock the parts in the storage case when not in use.
8. Save the shipping cartons and plastic foam blocks. You will find them very useful if you need to repack the processor for moving or other shipment. **NOTE:** We recommend that you visit our website, www.cuisinart.com for a fast, efficient way to complete your product registration.

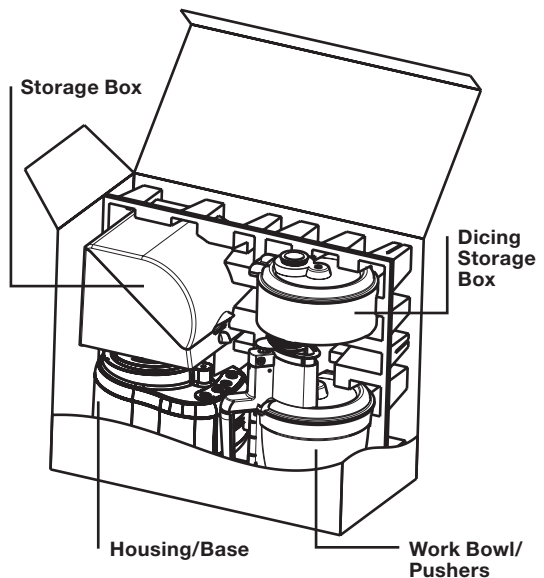
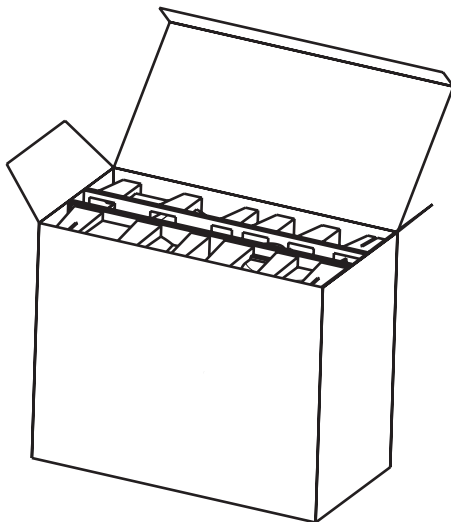

IMPORTANT SAFEGUARDS

Always follow these safety precautions when using this appliance.

Getting Ready

1. Read all instructions.
2. **Blades and discs are sharp.** Handle them carefully.
3. **Always unplug from outlet when not in use, before putting on or taking off parts, before removing food and before cleaning. To unplug, grasp plug and pull from electrical outlet. Never pull cord.**
4. Do not use outdoors.
5. Do not let cord hang over edge of table or counter, or touch hot surfaces.
6. Do not operate any appliance with a damaged cord or plug, or after appliance has been dropped or damaged in any way. Return appliance to the nearest authorized service facility for examination, repair or electrical or mechanical adjustment.

Operation

1. Keep hands as well as spatulas and other utensils away from moving blades or discs while processing food to prevent the possibility of severe personal injury or damage to food processor. A plastic scraper may be used, but only when the food processor motor is stopped.
2. Avoid coming into contact with moving parts. Never push food down by hand when slicing or shredding. Always use pusher.
3. Make sure motor has completely stopped before removing cover. (If machine does not stop within 4 seconds after you remove the bowl cover assembly, call 1-800-762-0190 for assistance. Do not use the machine.)
4. Never store any blade or disc on motor shaft. To reduce the risk of injury, no blade or disc should be placed on the shaft except when the bowl is properly locked in place and the processor is in use. Store blades and discs out of reach of children.
5. Be sure cover and feed tube are securely locked in place before operating food processor.
6. Never try to override or tamper with cover interlock mechanism.

Cleaning

1. To protect against risk of electrical shock, do not put base in water or other liquids.

General

1. This appliance should not be used by or near children or individuals with certain disabilities.
2. Do not operate this, or any other motor-driven appliance, while under the influence of alcohol or other substances that affect your reaction time or perception.
3. This food processor is ETL listed for household use. Use it only for food preparation as described in the accompanying recipe and instruction book. Do not use this appliance for anything but its intended use.
4. The use of attachments not recommended or sold by Cuisinart may cause fire, electrical shock or personal injury, or damage to your food processor.
5. To avoid possible malfunction of work bowl switch, never store processor with cover assembly in locked position.
6. Maximum rating of 550 watts is based on shredding disc, which the draws greatest current. Other recommended attachments may draw significantly less current.
7. Do not operate your appliance in an appliance garage or under a wall cabinet. **When storing in an appliance garage, always unplug the unit from the electrical outlet.** Not doing so could create a risk of fire, especially if the appliance touches the walls of the garage or the door touches the unit as it closes.
NOTICE: This appliance has a plastic case, it has a polarized plug (one blade is wider than the other). As a safety feature, this plug will fit in a polarized outlet only one way. If the plug does not fit fully in the outlet, reverse the plug. If it still does not fit, contact a qualified electrician. Do not attempt to defeat this safety feature.

SAVE THESE INSTRUCTIONS

FOR HOUSEHOLD USE ONLY

WARNING: RISK OF FIRE OR ELECTRIC SHOCK



The lightning flash with arrowhead symbol within an equilateral triangle is intended to alert the user to the presence of uninsulated, dangerous voltage within the product's enclosure that may be of sufficient magnitude to constitute a risk of fire or electric shock to persons.



The exclamation point within an equilateral triangle is intended to alert the user to the presence of important operating and maintenance (servicing) instructions in the literature accompanying appliance.

NOTICE

This appliance has a polarized plug (one blade is wider than the other). To reduce the risk of electric shock, this plug will fit into a polarized outlet only one way. If the plug does not fit fully into the outlet, reverse the plug. If it still does not fit, contact a qualified electrician. Do not modify the plug in any way.

CONTENTS

Important Unpacking Instructions.....	3
Important Safeguards.....	4
Features and Benefits	6-7
Accessory Storage Cases.....	8
General Assembly Instructions	9
Chopping/Mixing Blades.....	10
Slicing/Shredding Discs	10
Dough Blade.....	12
Dicing	13
Cleaning, Storage and Maintenance.....	14
For Your Safety.....	14
Technical Data.....	14
Troubleshooting.....	15
Warranty Information.....	17
Recipes.....	18-64



WARNING

**RISK OF FIRE OR ELECTRIC SHOCK
DO NOT OPEN**



**WARNING: TO REDUCE THE RISK OF FIRE OR ELECTRIC SHOCK,
DO NOT REMOVE COVER (OR BACK)
NO USER-SERVICEABLE PARTS INSIDE
REPAIR SHOULD BE DONE BY AUTHORIZED SERVICE PERSONNEL ONLY**

FEATURES AND BENEFITS

1. 3-Part Pusher Assembly

A small pusher (1a) sits inside the medium pusher (1b), which sits inside the large pusher (1c), allowing you to accommodate ingredients of all sizes. The large pusher lock can be pulled out to lock the large pusher, and pushed in to unlock it. This feature should be used when processing heavy loads or dicing.

2. Work Bowl Cover with Supreme® Wide-Mouth Feed Tube

Cover features SealTight™ Advantage feature, allowing maximum bowl capacity during processing and pouring. Exclusive feed tube accommodates larger ingredients and saves time precutting.

3. Small 4½-Cup (3a) and Large 13-Cup (3b) Work Bowls

Designed for maximum versatility, select the appropriate work bowl for the task.

4. Touchpad Control Panel

These easy-to-clean buttons feature High, Low, Off and Pulse options for every food processing function.

5. Housing Base and Motor

The heavy-duty base houses a powerful 550-watt motor and vertical motor shaft that processes a variety of recipes without slowing down.

6. Small Chopping/Mixing Blade

The small stainless steel blade chops or mixes ingredients in your small work bowl – features Cuisinart's BladeLock System.

7. Dough Blade

Designed to gently knead through all types of dough. Low speed is recommended when kneading. **NOTE:** The dough blade can only be used in the large bowl.

8. Large Chopping/Mixing Blade

This heavy-duty stainless steel blade will process a variety of food in your large work bowl. The BladeLock System keeps the blade in place to provide optimal ease when pouring. **NOTE:** Large bowl has a sealed drive system that eliminates any leaks.

9. Adjustable Slicing Disc

The versatile 7-in-1 disc allows for thin to thick slices with 1mm to 7mm indicators. This disc may be used only in the large bowl.

10. Reversible Shredding Disc

Provides the option of either fine or medium shredding for optimal results. This disc may be used only in the large bowl.

11. Stem Adapter

This user-friendly tool easily attaches to either disc, small chopping/mixing blade or Dicing Grid and Dicing Disc to engage the motor shaft.

12. Spatula

Uniquely designed for use with either work bowl.

13. Accessory Storage Case

This convenient storage case with safety lock holds all of the blades, discs and stem adapter that are included with your new food processor.

14. Dicing Kit

a. Cleaning Tool

Makes quick work of removing food trapped in dicing grid.

b. Flat Work Bowl Cover with Small Pusher

This dual-function work bowl cover is also the lid of the Dicing Kit's storage case.

c. Dicing Disc

Cuts food as it is pushed through grid.

d. Dicing Grid

Designed to position food to be cut into perfect squares.

e. Storage Case

Safely stores all the parts of the Dicing Kit.

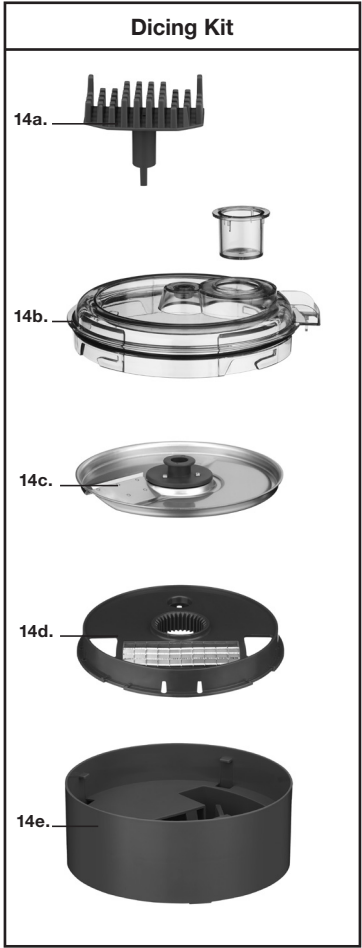
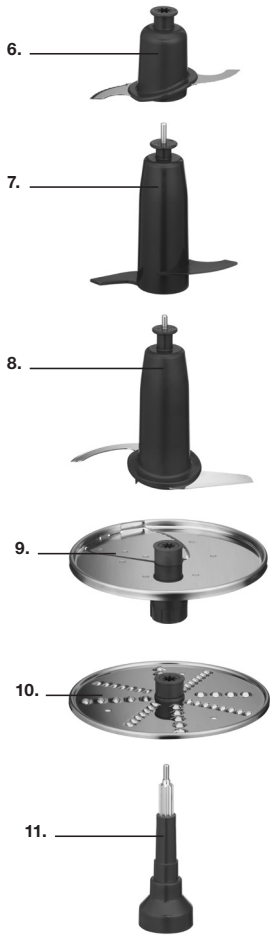
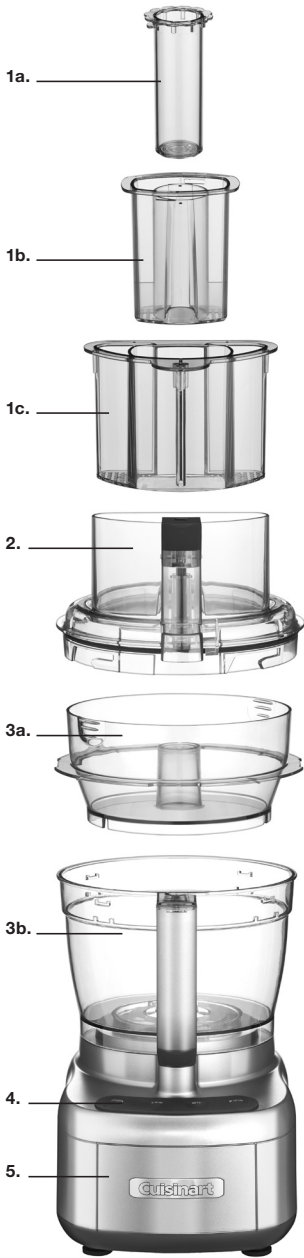

ACCESSORY STORAGE CASE

Operating the Lock

To unlock, turn counterclockwise. Gently lift up the transparent cover. Do not force the cover open when the knob is in the locked position. To lock, gently close the cover and turn the knob clockwise.

Inserting Accessories

The Accessory Storage Case holds the small chopping/mixing blade (A) on the peg in the back of the case, the dough blade (B) on the middle peg, the stem adapter (C) on the front peg, the large chopping/mixing blade (D) in the front cavity, the adjustable slicing disc (E) in the slot on the right, the reversible shredding disc (F) in the left slot.

Carefully hold discs by center hub when inserting into and removing from the storage case.

NOTE: DO NOT TOUCH METAL BLADES OR CUTTING EDGES OF DISCS. ALL ARE EXTREMELY SHARP AND CONTACT COULD CAUSE INJURY.

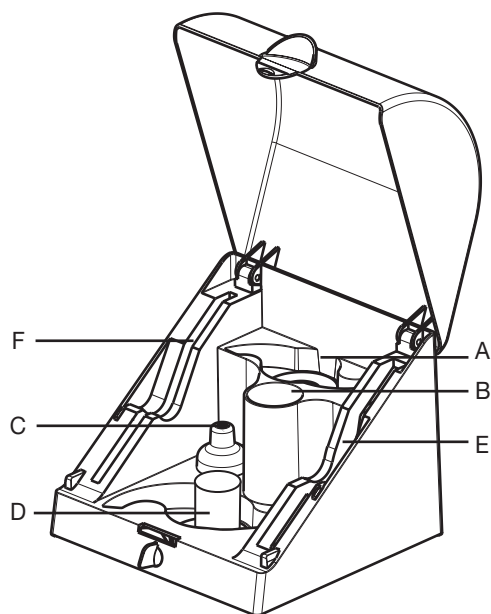

DICING KIT STORAGE CASE

Removing Parts

1. To open kit, turn the flat work bowl cover with small pusher counterclockwise and lift to remove.
2. Grasp center knob on dicing blade and carefully lift out of storage case. Set aside on a flat surface.
3. Using the openings in the top of dicing grid, grip and lift out to remove. See page 9 for assembly instructions.
4. The cleaning tool sits in a dedicated space in the base of the storage case.

NOTE: When finished dicing, wash, thoroughly dry and reverse order of directions above to return parts to storage case.

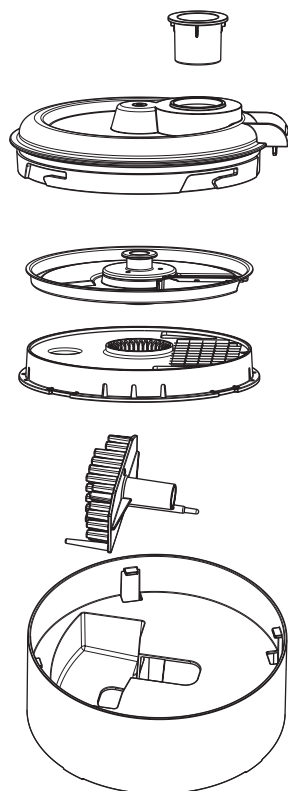

GENERAL ASSEMBLY INSTRUCTIONS

Before First Use

Before using your Cuisinart® Elemental™ 13-Cup Food Processor for the first time, wash all the parts (see Cleaning, Storage and Maintenance Instructions on page 14).

1. Place the food processor base on a dry, level countertop with the controls facing toward you. Do not plug the unit in until it is fully assembled.

Note: To use the small bowl, it must be nested in the large bowl with the stem adapter in place for operation.

2. Place the large work bowl on the base and use the handle to turn the bowl counterclockwise to lock it into place.
3. To use the small work bowl, first attach the large work bowl to the base. Place the stem adapter onto the shaft, then lower the small work bowl over the adapter and into the large bowl. Place your fingers in the recesses of the small bowl and turn slightly to secure in place.

Main Work Bowl Cover Operation

1. Place the lid over the work bowl with the feed-tube assembly shifted slightly to the right of the handle. Be sure to assemble the hub pin into the center of the lid.
2. Once the cover is fully seated, rotate the cover to the left (clockwise) to engage the lid locking mechanism and interlock.
3. To remove the lid, rotate the lid approximately $\frac{1}{12}$ th of a turn to the right to disengage the interlock and locking mechanism.



Flat Work Bowl Cover Operation

Use the Flat Cover for added convenience when your recipe calls for chopping, mixing, puréeing or kneading. It is particularly useful when you are preparing baked goods such as cakes, cookies, pies and breads.

To Assemble the Flat Cover

Begin with the work bowl and the metal blade in place. Place the Flat Cover on the work bowl so that the **Cuisinart logo written on the cover** is face up and readable. Then turn cover **CLOCKWISE** to lock into place.

Make sure the small cap is in place before using.

To Disassemble the Flat Cover

Place one hand near the Cuisinart logo and one hand on opposite end of cover; turn cover **COUNTERCLOCKWISE**. Lift cover up and off work bowl. Do not use the Flat Cover with any of the slicing or shredding discs. Use only with the metal blade or dough blade.

Work Bowls

The two nested work bowls offer versatile food processing options and save you time by minimizing cleanup. Use only the small work bowl when processing smaller quantities. Optimize efficiency when making recipes that require multiple bowls, by starting with the smaller work bowl. For example, prepare a crumb topping before mixing batter for a cake in the large work bowl. Or emulsify dressing before shredding broccoli, carrots and cabbage for vegetable slaw. Chopping certain foods may scratch or cloud the work bowl; this will not affect the functionality of your work bowl.

Machine Controls

High and Low Control Buttons

The High and Low controls are buttons that allow the machine to run until Off is selected.

1. Properly assemble the machine.
2. Add ingredients to the work bowl, either through the feed tube or directly into the bowl. Lock lid into place.
3. Press the High or Low button. The motor will start.
4. Press the Off button when finished.

Pulse Button

The Pulse control is a button that allows the machine to run only while it is being pressed. This capability provides more accurate control of the duration and frequency of processing. Unless otherwise specified, a pulse should be about two seconds.

With the machine properly assembled and engaged, and ingredients in the work bowl, press the Pulse button repeatedly as needed.

CHOPPING/ MIXING BLADES

Blade Operation

The BladeLock feature is designed to keep the blade in place during processing, pouring, lifting, and handling tasks — but is not permanently attached. **Handle with care. Always check to be sure the blade is securely locked before turning the bowl upside down.**

Large Blade Operation

With your large work bowl assembled on the base, grasp the large chopping/mixing blade by its hub, align it over the center of the bowl, place it onto the shaft and push down until it locks into place. Always check to be sure the blade is securely locked before turning the bowl upside down. (To remove, first take the bowl off the base and put it on a flat surface. Rest the heel of your hand on the rim of the bowl and pull up gently and carefully.)

Small Blade Operation

With the large work bowl in place on the base, place the stem adapter onto the hub in the center of the bowl. Next, put the small work bowl into the large bowl, positioning it over the adapter. Grasp the small chopping/mixing blade by its hub, placing it on the stem adapter. Push down firmly to lock. (To remove, first take the bowl off the base and put it on a flat surface. Rest the heel of your hand on the rim of the bowl and pull up gently and carefully.)

Small Bowl & Accessories



Chopping (using the Chopping/Mixing Blade)

- For raw ingredients: Peel, core and/or remove seeds and pits. Food should be cut into even, 1/2- to 1-inch pieces. Foods cut into same size pieces produce the most even results.
- Pulse food in 1 to 2 second increments to chop. For the finest chop, either hold the Pulse button down or press High or Low to run the machine continuously. Watch ingredients closely to achieve

desired consistency and scrape the work bowl as necessary. Low speed is recommended for making doughs and batters. High speed is recommended for most other chopping, processing and slicing/shredding tasks.

Puréeing (using the Chopping/Mixing Blade)

- To purée fresh fruits or cooked fruits/vegetables: Ingredients should be cut into 1-inch pieces; a smooth purée is best achieved when all the pieces are equal in size. Pulse to initially chop and then process High or Low until food is puréed; scrape the work bowl as necessary. Do not use this method to purée cooked white potatoes.
- To purée solids for a soup or sauce: Strain the solids from the liquid and process the solids alone. Add cooking liquid through the feed tube and process as needed.

SLICING/SHREDDING DISCS

Disc Operation

When using the large bowl, position the stem adapter onto the shaft. If using the adjustable slicing disc, use the rotating hub and indicator markings to select slicing thickness. Use the plastic hub, align and insert the disc over the stem adapter.

If using the reversible shredding disc, determine whether the fine or medium side will be used and use the plastic hub to twist into position on the stem adapter. The plastic hub may be used for removal of this disc.

Shredding & Slicing Accessories



Using the Adjustable Slicing and Reversible Shredding Discs

- The slicing disc makes whole slices. It slices fruits and vegetables, cooked meat and semi-frozen raw meat. The shredding disc shreds most firm and hard cheeses. It also shreds vegetables like potatoes, carrots and zucchini.
- Always pack food in the feed tube evenly for slicing and shredding. The food will dictate the amount of

pressure: Use light pressure for soft foods, medium pressure for medium foods and firm pressure for harder foods. Always process with even pressure.

- For round fruits or vegetables, slice a thick piece off base so it sits upright in feed tube. Slice to fit tube if necessary.
- For small ingredients like mushrooms, radishes or strawberries: Trim the ends so the food sits

upright in the feed tube.

- When slicing or shredding cheese, be sure that it is well chilled.
- To shred leafy vegetables like lettuce or spinach: Roll leaves together and stand them up in feed tube. Process with even pressure.

NOTE: Always use the pusher when slicing or shredding. Never put your fingers in the feed tube while unit is running.

Large Bowl & Accessories



USER GUIDE

You can slice, shred and chop a multitude of vegetables and fruits in the Cuisinart® Food Processor. What you may not know is that the food processor is the perfect tool for a number of other tasks, such as softening butter, making breadcrumbs, making baby food, etc. Here is a guide that will help you in preparing just about anything!

FOOD	TOOL	SPEED	DIRECTIONS
Soft Cheeses (ricotta, cream cheese, cottage cheese, etc.)	Chopping/Mixing Blade	Low to gently mix or High to whip	Have cheese at room temperature. When applicable, cut into 1-inch pieces. Process until smooth, stopping to scrape down the sides of the bowl as needed. Perfect for making cheesecakes, dips, pasta fillings and more.
Firm Cheeses (Cheddar, Swiss, Edam, Gouda, etc.)	Slicing or Shredding Disc	High	Cheese should be well chilled before slicing/shredding. Cut to fit feed tube. Use light to medium pressure when slicing/shredding.
Hard Cheeses (Parmesan, Romano, etc.)	Chopping/Mixing Blade Slicing or Shredding Disc	Pulse and High	If using the chopping blade, cut into ½-inch pieces. Pulse to break up and then process until finely grated. This will produce a nice grated cheese. If slicing or shredding, cut to fit feed tube. Use light to medium pressure when slicing/shredding.
Baby Food	Chopping/Mixing Blade	Pulse and High	As for all fruit and vegetable purées, cut ingredients into ½- to 1-inch pieces. Steam ingredients until completely soft. Pulse to chop, then process until completely smooth (add steaming liquid through the feed tube when processing if necessary). Keeps frozen in ice cube trays for individual 1-ounce portions.
Butter	Chopping/Mixing Blade Slicing or Shredding Disc	High	<i>For creaming:</i> Have butter at room temperature. Cut into 1-inch pieces. Process, scraping bowl as necessary. For compound (flavored) butters, process flavoring ingredients, such as herbs, zest, vegetables, etc., before adding butter. <i>For shredding/slicing:</i> Freeze briefly. Use light to medium pressure to shred or slice. Shredded butter is great for preparing certain pastry doughs. Sliced butter is great for serving alongside corn on the cob or freshly made rolls.

FOOD	TOOL	SPEED	DIRECTIONS
Crumbs (Bread, Cookie, Cracker, Chip)	Chopping/Mixing Blade	Pulse and High	Break into pieces. Pulse to break up, and then process until desired consistency. This will make perfect bread/cracker/chip crumbs for coating meats and fish. Processed cookies make delicious pie and cake crusts.
Fresh Herbs	Chopping/Mixing Blade	Pulse	Wash and dry herbs thoroughly. Pulse to roughly chop. Continue pulsing until desired consistency is achieved.
Ground Meat	Chopping/Mixing Blade	Pulse	Cut meat into 1-inch pieces. Pulse to chop, about 25 long pulses, or until desired consistency is achieved. If a purée is desired, continue to process. Never chop/purée more than 2 pounds at one time. Make sure to never process meat containing bones.
“Ice Cream”	Chopping/Mixing Blade	Pulse and High	Put frozen fruit cut into 1-inch pieces into the work bowl, with liquid (juice or milk), any desired sweeteners, such as sugar, honey, simple syrup and other flavors. Pulse to break up. Process until smooth.
Milk Shakes/Smoothies	Chopping/Mixing Blade	Low	For milk shakes, first add ice cream. While unit is running, add milk through the feed tube until desired consistency is achieved. For smoothies, add fruit first, then add the liquid through the feed tube while unit is running.
Nuts	Chopping/Mixing Blade	Pulse and High	Pulse to chop to desired consistency. To make a nut butter, pulse to break up, and then process until smooth, stopping to scrape down as needed.
Superfine Sugar	Chopping/Mixing Blade	High	Process granulated sugar for about 1 minute until finely ground. Excellent for using in meringues and other baked goods.
Whipped Cream	Chopping/Mixing Blade	Low	Process well-chilled cream until cream begins to thicken. Add sugar as desired; process continuously until cream reaches desired consistency. This cream is dense and perfect as a whipped topping for cake or ice cream.

DOUGH BLADE

Dough Blade Operation

For use with the large bowl. Carefully place the dough blade on the shaft and push to lock into place.

Kneading

(using the Dough Blade or the Chopping/Mixing Blade with Low Speed)

- The chopping blade is ideal for pastry doughs,

while the dough blade is specifically designed for kneading yeast doughs.

- The large pusher lock is recommended to be in the locked position when kneading dough to avoid it from moving around — some vibration is still normal.
- Dough kneading should be done in the large bowl only.

DICING

Assembling the Dicer in Work Bowl

1. With large work bowl on base, insert stem adapter.
2. Carefully place Dicing Grid onto the stem adapter with the grid positioned closest to the front of the food processor. Be sure “This Side Up” shows on top. The cutting grid should be facing with the triangle on front of the grid, aligned with the center of the work bowl handle. Dicer will not work if inserted incorrectly.

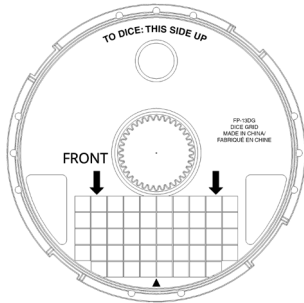

3. Carefully place dicing blade on top of grid. Push down slightly to lock into place. It should not move if positioned accurately. **NOTE:** Always use caution when handling the dicing blade; it is very sharp.
4. Follow instructions under Cover Operation to lock cover onto work bowl.

Dicing Kit & Accessories



Using Dicing Kit

- The dicing disc and grid make cubed pieces of fruit and vegetables. The recommended speed for dicing most fruits and vegetables is High. Use Low speed when dealing with very soft items such as kiwi.
- When dicing, only use the **medium** or **small** feed tube. Be sure to pack single items tightly, to the left of the feed tube using consistent downward pressure.
- **Use the cleaning tool to clear the grid.** First dislodge jammed particles using the long single tooth on the handle. Then align the two long pins along the right and left of the grid. Guide the cleaner into the correct position and press down to clear the grid of food residue.
- When processing items like carrots, squash and potatoes, clean the grid every 3 to 4 times to prevent buildup.
- When large pieces of food remnants are lying between the grid and disc, use caution when cleaning off the remains by using the gaps featured to the right and left of the grid.

NOTE:

We do not recommend dicing frozen foods and meats. For dicing use medium or small pusher only.

TIP:

Always process foods from soft (kiwi) to hard (potato).

DICING GUIDE

FOOD	TOOL	SPEED	DIRECTIONS
Most Vegetables (e.g., Potato, Zucchini)	Dicing Kit	High	Peel vegetables if necessary, and trim to fit small or medium feed tube before dicing.
Soft/Very Ripe Vegetables (e.g., Ripe Tomatoes and Avocados)	Dicing Kit	Low	Peel vegetables if necessary, and trim to fit small or medium feed tube before dicing.
Most Fruits (e.g., Apples, Bananas, Strawberries)	Dicing Kit	High	Peel fruit if necessary, and trim to fit small or medium feed tube before dicing.
Soft/Very Ripe Fruits (e.g., Kiwi, Ripe Pineapple, Very Ripe Bananas)	Dicing Kit	Low	Peel fruit if necessary, and trim to fit small or medium feed tube before dicing.

CLEANING, STORAGE AND MAINTENANCE

- Keep your Cuisinart® Elemental™ 13-Cup Food Processor ready to use on the kitchen counter. When not in use, leave it unplugged.
- Keep the blades and discs out of reach of children.
- All parts except the housing base are dishwasher safe, and we recommend washing them in the dishwasher on the **top rack only**. Due to intense water heat, washing the work bowl, cover and accessories on the bottom rack may cause damage over time. Insert the cover with the feed tube facing up to ensure proper cleaning. Insert the work bowl and pusher upside down for drainage. Remember to unload the dishwasher carefully wherever you have placed sharp blades and discs.
- To simplify cleaning, rinse the work bowl, cover, pusher and blade or disc immediately after use so food won't dry on them. Be sure to position the pusher upside down for drainage. If food lodges in the pusher, remove it by running water through it, or use a bottle brush.
- If you wash the blades and discs by hand, do it carefully. When handling, use the plastic hubs. Avoid leaving them in soapy water where they may disappear from sight. To clean the blades, fill the work bowl with soapy water, hold the blade by its plastic center and move it rapidly up and down on the center shaft of the bowl. Use of a spray attachment is also effective. If necessary, use a brush.
- The work bowl is made of SAN plastic with metal components. It should not be placed in a microwave oven.
- The housing base may be wiped clean with a soapy, nonabrasive material. Be sure to dry it thoroughly.
- If the feet leave spots on the counter, spray them with a spot remover and wipe with a damp sponge.
- If any trace of the spot remains, repeat the procedure and wipe the area with a damp sponge and nonabrasive cleaning powder.

IMPORTANT: Never store any blade or disc on the motor shaft. No blade or disc should be placed on the shaft except when the processor is about to be used.

MAINTENANCE: Any other servicing should be performed by an authorized service representative.

FOR YOUR SAFETY

- Like all powerful electrical appliances, a food processor should be handled with care. Follow these guidelines to protect yourself and your family from misuse that could cause injury.
- Handle and store blades and discs carefully. Their cutting edges are very sharp.
- Never put blades or discs on the motor shaft until the work bowl is locked in place.
- Always be sure that the blade or disc is down on the motor shaft as far as it will go.
- Always insert the blade in the work bowl before putting ingredients in bowl.
- When slicing, shredding or dicing food, always use the pusher. Never put your fingers or spatula into feed tube.
- Always wait for the blade or disc to stop spinning before you remove the pusher assembly or cover from the work bowl.
- Always unplug the unit before removing food, cleaning or putting on or taking off parts.
- Always remove work bowl from base of machine before you remove the blade.
- Be careful to prevent the chopping/mixing blade from falling out of the work bowl when emptying the bowl. Remove it before tilting the work bowl.

TECHNICAL DATA

The motor in your food processor operates on a standard line operating current. The appropriate voltage and frequency for your machine are shown on a label on the bottom of the base.

An automatic, temperature-controlled circuit breaker in the motor ensures complete protection against motor burnout. If the processor runs for an exceptionally long time when chopping, mixing or kneading a thick or heavy mixture in successive batches, the motor may overheat. If this happens, the processor will stop. Turn it off and wait for the motor to cool before proceeding. It will usually cool within 10 minutes. In extreme cases, it could take an hour.

Safety switches prevent the machine from operating when the work bowl or the cover is not locked into position. The motor stops within seconds when the motor is turned off; and when the pusher assembly is removed, a fast-stop circuit also enables the motor to stop within seconds.

Cuisinart offers a Limited Three-Year Warranty on the entire machine.

TROUBLESHOOTING

Food Processing

- 1. Problem:** The food is unevenly processed when chopping.

Solution:

- The ingredients should be cut evenly into ½- to 1-inch pieces before processing.
- Process in batches to avoid overloading.

- 2. Problem:** Slices are uneven or slanted.

Solution:

- Place evenly cut food, cut side down, into the feed tube. Pack if possible. Always use the smallest feed tube possible.
- Apply even pressure on the pusher.

- 3. Problem:** Food falls over in feed tube.

Solution:

- Feed tube should be packed full for best results.

- 4. Problem:** Some food remains on top of the disc.

Solution:

- It is normal for small pieces to remain; cut remaining bits by hand and add to processed ingredients.

Dicing Kit

- 1. Problem:** Food is stuck in the grid.

Solution:

- First, unplug unit. Carefully remove Dicing Disc. Then, carefully reach into the large openings on either side of grid to remove large food pieces.
- Do not use your fingers to clean the grid. **ONLY USE THE CLEANING TOOL.**
- Use the long single tooth on the cleaning tool handle to push stubborn food through grid.

- 2. Problem:** Pieces of food are not evenly cut.

Solution:

- Pack items closest to the left in medium or small feed tube.
- Use the small feed tube for smaller items.
- Apply even pressure when using feed tube.

Dough Kneading

- 1. Problem:** Motor slows down.

Solution:

- Amount of dough may exceed maximum capacity of your food processor. Remove half and process in two batches.

- Dough may be too wet (see number 8). If motor speeds up, continue processing. If not, add more flour, 1 tablespoon at a time, until the motor speeds up. Process until dough cleans the sides of the work bowl.

- 2. Problem:** Blade doesn't incorporate ingredients.

Solution:

- Always start the food processor before adding liquid. Add liquid in a slow, steady stream, or through the drizzle hole in the pusher, allowing the dry ingredients to absorb it. If liquid is added too quickly, wait until ingredients in the work bowl have mixed, then add remaining liquid slowly (do not turn off the machine). Pour liquid onto dough as it passes under feed tube opening; do not pour liquid directly onto bottom of the work bowl.

- 3. Problem:** Blade rises in work bowl.

Solution:

- Excessively sticky dough can cause blade to rise. Carefully reinsert blade and immediately add 2 tablespoons of flour through the feed tube while the machine is running.

- 4. Problem:** Dough doesn't clean inside of the work bowl.

Solution:

- Amount of dough may exceed maximum capacity of your food processor. Remove half and process in two batches.
- Dough may be too dry (see number 7).
- Dough may be too wet (see number 8).

- 5. Problem:** Nub of dough forms on top of blade and does not become uniformly kneaded.

Solution:

- Stop machine, carefully remove dough, divide it into 3 pieces and redistribute them evenly in the work bowl.

- 6. Problem:** Dough feels tough after kneading.

Solution:

- Divide dough into 2 or 3 pieces and redistribute evenly in bowl. Process 10 seconds or until uniformly soft and pliable.

- 7. Problem:** Dough is too dry.

Solution:

- While machine is running, add water, 1 tablespoon at a time, until dough cleans the inside of the bowl.

- 8. Problem:** Dough is too wet.

Solution:

-
- While machine is running, add flour, 1 tablespoon at a time, until dough cleans the inside of the bowl.

Technical

1. Problem: The motor does not start.

Solution:

- There is a safety interlock to prevent the motor from starting if it is not properly assembled. Make sure the work bowl and work bowl cover are securely locked into position.
- If the motor still will not start, check the power cord and outlet.

2. Problem: The food processor shuts off during operation.

Solution:

- The cover may have become unlocked; check to make sure it is securely in position.
- A safety protector in the motor prevents the motor from overheating, which is caused by excessive strain. Press the Off control button and wait 10 minutes to allow the food processor to cool off before resuming.

3. Problem: The motor slowed down during operation.

Solution:

- This is normal as some heavier loads (e.g., slicing/shredding cheese) may require the motor to work harder. Simply reposition the food in the feed tube and try again.
- The maximum load capacity may have been exceeded. Remove some of the ingredients and continue processing.

4. Problem: The food processor vibrated/moved around the countertop during processing.

Solution:

- Make sure the rubber feet at the bottom of the unit are clean and dry. Also make sure that the maximum load capacity is not being exceeded.
- This is normal as some heavier loads (e.g., slicing/shredding cheese) may require the motor to work harder.

LIMITED THREE-YEAR WARRANTY (U.S. AND CANADA ONLY)

This warranty is available to consumers only. You are a consumer if you own a Cuisinart® Elemental™ 13-Cup Food Processor that was purchased at retail for personal, family or household use. Except as otherwise required under applicable law, this warranty is not available to retailers or other commercial purchasers or owners.

We warrant that your Cuisinart® Elemental™ 13-Cup Food Processor will be free of defects in materials and workmanship under normal home use for three years from the date of original purchase.

We recommend that you visit our website, www.cuisinart.com for a fast, efficient way to complete your product registration. However, product registration does not eliminate the need for the consumer to maintain the original proof of purchase in order to obtain the warranty benefits. In the event that you do not have proof of purchase date, the purchase date for purposes of this warranty will be the date of manufacture.

If your Cuisinart® Elemental™ 13-Cup Food Processor should prove to be defective within the warranty period, we will repair it, or if we think necessary, replace it. To obtain warranty service, simply call our toll-free number 1-800-726-0190 for additional information from our Customer Service Representatives, or send the defective product to Consumer Service at Cuisinart, 7475 North Glen Harbor Blvd., Glendale, AZ 85307.

To facilitate the speed and accuracy of your return, please enclose \$10.00 for shipping and handling of the product.

Please pay by check or money order made payable to Cuisinart (California residents need only supply proof of purchase and should call 1-800-726-0190 for shipping instructions).

NOTE: For added protection and secure handling of any Cuisinart product that is being returned, we recommend you use a traceable, insured delivery service. Cuisinart cannot be held responsible for in-transit damage or for packages that are not delivered to us. Lost and/or damaged products are not covered under warranty. Please be sure to include your return address, daytime phone number, description of the product defect, product model number (located on bottom of product), original date of purchase and any other information pertinent to the product's return.

Your Cuisinart® Elemental™ 13-Cup Food Processor has been manufactured to the strictest specifications and has been designed for use only in 120 volt outlets and only with authorized accessories and replacement parts. This warranty expressly excludes any defects or damages caused by attempted use of this unit with a converter, as well as use with accessories, replacement parts or repair service other than those authorized by Cuisinart. This warranty does not cover any damage caused by accident, misuse, shipment or other than ordinary household use. This warranty excludes all incidental or consequential damages. Some states do not allow the exclusion or limitation of these damages, so these exclusions may not apply to you.

You may also have other rights, which vary from state to state.

CALIFORNIA RESIDENTS ONLY

California law provides that for In-Warranty Service, California residents have the option of returning a nonconforming product (A) to the store where it was purchased or (B) to another retail store that sells Cuisinart products of the same type.

The retail store shall then, at its discretion, either repair the product, refer the consumer to an independent repair facility, replace the product, or refund the purchase price less the amount directly attributable to the consumer's prior usage of the product. If the above options do not result in the appropriate relief to the consumer, the consumer may then take the product to an independent repair facility if service or repair can be economically accomplished. Cuisinart and not the consumer will be responsible for the reasonable cost of such service, repair, replacement, or refund for nonconforming products under warranty.

California residents may also, according to their preference, return nonconforming products directly to Cuisinart for repair, or if necessary, replacement, by calling our Consumer Service Center toll-free at 1-800-726-0190.

Cuisinart will be responsible for the cost of the repair, replacement, and shipping and handling for such products under warranty.

BEFORE RETURNING YOUR CUISINART PRODUCT

If you are experiencing problems with your Cuisinart product, we suggest that you call our Consumer Service Center at 1-800-726-0190 before returning the product to be serviced.

If servicing is needed, a Representative can confirm whether the product is under warranty and direct you to the nearest service location.

Important: If the nonconforming product is to be serviced by someone other than Cuisinart's Authorized Service Center, please remind the servicer to call our Consumer Service Center at 1-800-726-0190 to ensure that the problem is properly diagnosed, the product is serviced with the correct parts, and the product is still under warranty.

©2016 Cuisinart
150 Milford Road
East Windsor, NJ 08520
Printed in China

16CE018594

IB-14149-ESP

RECIPES

To help your Cuisinart Elemental 13 Food Processor feel right at home in your kitchen, we've assembled a variety of delicious recipes to get you started, from quick and easy to more complex gourmet dishes. Breakfast and brunch through dinner and dessert, these easy-to-follow recipes make sure every meal is covered.

Look for the chef's whisks above the ingredients for the degree of difficulty (1=easy, 2=medium, 3=challenging).

In addition, the detailed nutritional information lets you know exactly what you're eating!

Bon appétit!

BASICS

Breadcrumbs (Plain and Seasoned)	20
Herb Butter	21
Basil Pesto	22
Simple Pizza and Tomato Sauce	23
Peanut Butter.....	24
Almond Butter.....	25
Mayonnaise.....	26
Basic Vinaigrette	27
Caesar Dressing	28
Baby Food	29

BREAKFAST/BRUNCH

Blueberry Cream Cheese.....	30
Morning Glory Muffins	31
Banana Nut Bread.....	32
Zucchini Frittata, Manchego and Ham.....	33
Home Fries	34
Rustic Potato and Fennel Tart	35

APPETIZERS & DRINKS

Hummus.....	36
Guacamole.....	37
Fire-Roasted Salsa.....	38
Crab Cakes	39

Potato Nachos.....	40
White Sangria.....	41

SOUPS & SALADS

Creamy White Bean Soup.....	42
Spring Vegetable Minestrone with Pesto.....	43
Pear and Kale Salad.....	44
Celery Root Salad with Tarragon Dressing.....	45
Potato Salad.....	46

MAIN COURSES & SIDES

Potato Pancakes.....	47
Falafel.....	48
Chicken Burgers with Mango-Avocado Salsa.....	49
Meatballs.....	50
Pineapple Fried Rice.....	51
Ratatouille.....	52
Brussels Sprouts with Lardons.....	53
Cauliflower-Crust Pizza.....	54
Sausage Rolls.....	55

BREADS & DOUGHS

Classic White Bread.....	56
Buttery Dinner Rolls.....	57
Pizza Dough.....	58
Flaky Pastry Dough.....	59

DESSERTS

Tropical Fruit Salad.....	60
Apple Tart.....	61
Double Chocolate Zucchini Bread.....	62
Pecan Shortbread Linzer Cookies.....	63
Strawberry Frozen Yogurt.....	64

BREADCRUMBS (PLAIN AND SEASONED)

There is no need to buy breadcrumbs when you can make them fresh in your Cuisinart® Food Processor.



8

SLICES WHITE BREAD

Makes about 2 cups

1. Preheat oven to 325°F. Arrange the bread on a sheet tray in a single layer. Bake until golden in color and completely dried out, about 20 minutes.
2. When the bread is dried out, break into large pieces and put into the large work bowl fitted with the large chopping blade. Pulse to break up, about 10 times. Process on High until fine and even in consistency, about 1 minute. Store in an airtight container until ready to use.

TIP: Making breadcrumbs is a great use for stale bread. Just break up and process as instructed above without baking first.

Note: For seasoned breadcrumbs, add ¼ teaspoon each dried oregano, dried basil, garlic powder and ground onion flakes to the work bowl with the dried-out bread.

Nutritional information per serving (2 tablespoons):

*Calories 60 (11% from fat) • carb. 11g • pro. 2g • fat 1g
sat. fat 0g • chol. 0mg • sod. 90mg • calc. 10mg • fiber 1g*

HERB BUTTER

Spruce up ordinary dishes with a dab of herb butter. It can be used in plain pastas, on vegetables, or to finish simply cooked steaks, fish and chicken.



- 1 SMALL GARLIC CLOVE, PEELED
- ½ SMALL BUNCH CHIVES (ABOUT ¼ OUNCE), CUT INTO 1-INCH PIECES
- 2 SPRIGS FRESH THYME, LEAVES ONLY
- 16 TABLESPOONS (2 STICKS) UNSALTED BUTTER, CUT INTO 1-INCH PIECES AND SOFTENED
- ½ TEASPOON KOSHER SALT

Makes 1 cup

1. Insert the small work bowl and small chopping blade. With the food processor running on High, drop the garlic through the small feed tube to finely chop. Scrape down the sides and add the chives and thyme leaves. Pulse to chop, about 5 to 6 times.
2. Add the butter and salt. Pulse to break up butter, about 5 to 6 times. Process on High until all the ingredients are fully combined, about 40 seconds.
3. Use herb butter immediately or transfer to a sheet of wax paper, shape into a log about 4 to 5 inches long, wrap and twist the ends in opposite directions to seal. Store in the refrigerator until ready to use.

TIP: Use this recipe as a guide for making any type of compound butter. Add a different assortment of herbs, chopped vegetables, crumbled bacon, or sweet ingredients like honey or cinnamon sugar.

Nutritional information per serving (1 tablespoon):

*Calories 100 (99% from fat) • carb. 0g • pro. 0g • fat 11g
sat. fat 8g • chol. 30mg • sod. 67mg • calc. 1mg • fiber 0g*

BASIL PESTO

For a spin on the traditional recipe, substitute the pine nuts in this recipe with toasted hazelnuts and the basil with 2½ ounces arugula and 1½ ounces baby spinach leaves.



- 2 OUNCES PARMESAN CHEESE, CUT INTO ½-INCH CUBES
- 1 GARLIC CLOVE, PEELED
- ¼ CUP PINE NUTS, LIGHTLY TOASTED
- 4 OUNCES FRESH BASIL LEAVES (ABOUT 3 CUPS)
- ¼ TEASPOON KOSHER SALT
- ½–⅔ CUP EXTRA VIRGIN OLIVE OIL

Makes about 1½ cups

1. Insert the large chopping blade into the large work bowl. With the food processor running on High, drop the Parmesan cubes and garlic through the small feed tube to finely chop. Add the pine nuts and pulse to chop, about 5 to 6 times. Add the basil and salt. Pulse to chop, about 10 to 15 times. Scrape the sides of the bowl.
2. With the machine running on High, add the olive oil in a steady stream through the small feed tube. Process until combined, about 1 minute.
3. Use immediately or store in an airtight container in the refrigerator until ready to use.

Nutritional information per serving (2 tablespoons):

*Calories 120 (90% from fat) • carb. 1g • pro. 2g • fat 13g
sat. fat 2g • chol. 3mg • sod. 121mg • calc. 74mg • fiber 0g*

SIMPLE PIZZA AND TOMATO SAUCE

The difference between pizza sauce and tomato sauce is that pizza sauce does not need to be cooked—it cooks on the pizza in the oven, while tomato sauce simmers on the stove.



- 2 CANS (28 OUNCES EACH)
WHOLE, PEELED TOMATOES
- 2 TABLESPOONS EXTRA VIRGIN
OLIVE OIL
- 2 LARGE GARLIC CLOVES, PEELED
- 10–15 FRESH BASIL LEAVES
- 1 TEASPOON KOSHER SALT

Makes 7 cups pizza sauce; about 5 cups tomato sauce

Pizza Sauce:

1. Put all of the ingredients, in the order listed, into the large work bowl fitted with the large chopping blade. Process on High until smooth, 1 minute.
2. Use as is for pizza or other recipes that will cook in the oven. Store remaining sauce in an airtight container in the refrigerator.

Tomato Sauce:

1. Put tomatoes into the large work bowl fitted with the large chopping blade. Process on High until smooth, about 1 minute. Reserve.
2. Put olive oil in a medium saucepan over medium heat. When oil is hot, add garlic and cook until lightly golden and fragrant, 2 to 3 minutes. Add puréed tomatoes, cover and reduce heat to simmer, stirring frequently, until sauce is reduced slightly until thickened, about 15 minutes.
3. Tear up basil and add to sauce; cook for 2 minutes. Add salt, taste and adjust seasoning as desired. Remove garlic cloves before serving.

Nutritional information per serving (½ cup pizza sauce):

*Calories 41 (61% from fat) • carb. 5g • pro. 1g • fat 2g
sat. fat 0g • chol. 0mg • sod. 398mg • calc. 36mg • fiber 1g*

Nutritional information per serving (½ cup tomato sauce):

*Calories 58 (43% from fat) • carb. 7g • pro. 1g • fat 3g
sat. fat 0g • chol. 0mg • sod. 557mg • calc. 28mg • fiber 1g*

PEANUT BUTTER

Once you discover how easy it is to make peanut butter in the Cuisinart® food processor, you'll wonder how you ever bought it jarred.



1 POUND (ABOUT 4 CUPS) UNSALTED, DRY-ROASTED PEANUTS

1 TEASPOON KOSHER SALT, OPTIONAL

Makes 2 cups

1. Put peanuts and salt, if using, into the large work bowl fitted with the large chopping blade. Pulse to break up, about 5 to 6 times. Process on High until desired consistency is achieved.

2. Taste and adjust seasoning as desired. Store in an airtight container in the refrigerator.

TIP: For a spiced variation, add 2 teaspoons honey, ½ teaspoon ground cinnamon, 1 teaspoon kosher salt (do not use if already added above), 1 teaspoon ground allspice and 1 teaspoon ground nutmeg.

Nutritional information per serving (1 tablespoon, unsalted):

*Calories 80 (61% from fat) • carb. 2g • pro. 4g • fat 7g
sat. fat 1g • chol. 0mg • sod. 3mg • calc. 36mg • fiber 1g*

ALMOND BUTTER

Try a combination of your favorite nuts to make the ultimate nut butter.



9 OUNCES (ABOUT 2 CUPS)
RAW, UNSALTED ALMONDS

3½ TABLESPOONS GRAPESEED OIL

1 TEASPOON KOSHER SALT,
OPTIONAL

Makes about 1¼ cups

1. Put almonds, oil and salt, if using, into the large work bowl fitted with the large chopping blade. Pulse to break up, about 10 times, and then process on High until desired consistency is achieved.
2. Taste and adjust seasoning as desired. Store in an airtight container in the refrigerator.

Nutritional information per serving (1 tablespoon, unsalted):

Calories 94 (78% from fat) • carb. 3g • pro. 3g • fat 9g
sat. fat 1g • chol. 0mg • sod. 0mg • calc. 34mg • fiber 2g

MAYONNAISE

Taste the difference in homemade mayonnaise.



- 4 LARGE EGG YOLKS
- $\frac{3}{4}$ TEASPOON KOSHER SALT
- $\frac{1}{2}$ TEASPOON DIJON MUSTARD
- 1 TEASPOON FRESH LEMON JUICE
- 1 TABLESPOON WATER
- $\frac{3}{4}$ CUP VEGETABLE OIL

Makes 1 cup

1. Put the egg yolks, salt, mustard, lemon juice and water into the large work bowl fitted with the large chopping blade. Process on Low until smooth, about 30 seconds.
2. With the food processor still running on Low, add the oil through the hole in the small pusher until all the oil is incorporated and the mayonnaise is emulsified and homogenous. Scrape down sides. Taste and adjust seasoning as desired. Store remaining mayonnaise in an airtight container in the refrigerator.

TIP: For fresh herb mayonnaise, process $\frac{1}{3}$ cup firmly packed fresh herbs (e.g., parsley, dill, tarragon, basil, etc.), stems removed, with the yolks before adding the oil.

For a bolder-flavored mayonnaise, increase the salt by $\frac{1}{4}$ teaspoon, the Dijon by $\frac{1}{2}$ teaspoon and lemon juice to 1 tablespoon.

Nutritional information per serving (1 tablespoon):

Calories 104 (97% from fat) • carb. 1g • pro. 1g • fat 12g
sat. fat 1g • chol. 46mg • sod. 113mg • calc. 6mg • fiber 0g

BASIC VINAIGRETTE

Use this basic vinaigrette as a guide and change your vinegar/oil flavors to create exciting salads. You can add other flavors such as crushed or roasted garlic, chopped shallots, fresh or dried herbs, sun-dried tomatoes, honey, lemon juice, or flavored vinegars.



- 1/4 CUP WINE VINEGAR
(RED OR WHITE)
- 1 TABLESPOON DIJON MUSTARD
- 3/4 CUP EXTRA VIRGIN OLIVE OIL
- KOSHER SALT AND FRESHLY
GROUND PEPPER TO TASTE

Makes about 1 cup

1. Put all of the ingredients into the small work bowl fitted with the small chopping blade. Process on Low until combined, about 1 minute.
2. Taste and adjust seasoning as desired. Serve immediately or store in an airtight container in the refrigerator.

Nutritional information per serving (1 tablespoon):

*Calories 91 (98% from fat) • carb. 0g • pro. 0g • fat 10g
sat. fat 1g • chol. 0mg • sod. 23mg • calc. 0mg • fiber 0g*

CAESAR DRESSING

There are many versions of this recipe, but our take is pretty close to the classic. If you prefer not to use raw egg yolks, try an egg substitute.



- 2 SMALL GARLIC CLOVES, PEELED
- 6 ANCHOVY FILLETS
- 2 LARGE EGG YOLKS*
- 2 TEASPOONS DIJON MUSTARD
- 4 TEASPOONS FRESH LEMON JUICE
- 4 TEASPOONS RED WINE VINEGAR
- 2 TEASPOONS WORCESTERSHIRE SAUCE
- 1/2 TEASPOON FRESHLY GROUND BLACK PEPPER
- 2/3 CUP EXTRA VIRGIN OLIVE OIL

Makes about 1 cup

1. Insert the large chopping blade into the large work bowl. With the food processor running on High, drop the garlic through the small feed tube to finely chop. Add the anchovies, egg yolks, mustard, lemon juice, vinegar, Worcestershire sauce and pepper to the work bowl. Process on High until well blended.
2. With the machine running on Low, slowly pour the olive oil through the small feed tube in a steady stream until the dressing is emulsified, about 30 seconds to 1 minute.
3. Taste and adjust seasoning as desired. Serve immediately or store in an airtight container in the refrigerator.

*Raw Egg Warning: Caution is suggested in consuming raw and lightly cooked eggs due to the slight risk of salmonella or other food-borne illnesses. To reduce this risk, we recommend you use only fresh, properly refrigerated, clean grade A or AA eggs with intact shells. Avoid contact between the yolks or whites and the shell.

Nutritional information per serving (1 tablespoon):

*Calories 91 (95% from fat) • carb. 1g • pro. 1g • fat 10g
sat. fat 2g • chol. 24mg • sod. 68mg • calc. 4mg • fiber 0g*

BABY FOOD

Any fruit or vegetable can be substituted. Add more or less liquid based on the consistency desired.



- 1 POUND BUTTERNUT SQUASH,
PEELED AND CUT TO FIT FEED TUBE
- 2 TABLESPOONS STEAMING LIQUID
OR WATER

Makes 2 cups

1. Insert dicing grid and blade. Dice butternut squash. Steam until very tender. Reserve steaming water.
2. Add the steamed butternut squash to the large work bowl fitted with the large chopping blade. Add 2 tablespoons of the reserved steaming water or plain water. Process on High until desired consistency is achieved, about 2 minutes for very smooth and creamy purée.

TIP: Store remaining baby food in covered ice cube trays in the freezer until ready to use. Each "cube" equals 1 ounce of food.

Nutritional information per serving (2 ounces):

*Calories 44 (33% from fat) • carb. 7g • pro. 1g • fat 2g
sat. fat 1g • chol. 6mg • sod. 165mg • calc. 0mg • fiber 2g*

BLUEBERRY CREAM CHEESE

Flavored cream cheese options are endless.
This one's versatile and not too sweet.



- 6 OUNCES (ABOUT 4¼ CUPS)
FRESH BLUEBERRIES
- 1 TEASPOON GRANULATED SUGAR
- 1 TEASPOON FRESH LEMON JUICE
- 1 PACKAGE (8 OUNCES) CREAM
CHEESE, CUT INTO 4 PIECES
AND SOFTENED

Makes 1½ cups

1. Put blueberries, sugar and lemon juice into a small saucepan and cook over low heat until blueberries are mostly broken down and mixture has thickened, about 5 to 6 minutes. Remove from heat and allow to cool to room temperature.
2. Put softened cream cheese pieces and cooled blueberry mixture into the small work bowl fitted with the small chopping blade. Pulse to break up cream cheese and mix in blueberry mixture, about 8 to 10 times.
3. Serve immediately or store in an airtight container in the refrigerator.

Nutritional information per serving (2 tablespoons):

*Calories 111 (77% from fat) • carb. 5g • pro. 2g • fat 10g
sat. fat 5g • chol. 31mg • sod. 92mg • calc. 29mg • fiber 1g*

MORNING GLORY MUFFINS

Your kids will never guess that the secret ingredient in these muffins is carrots—they add the perfect sweetness.



NONSTICK COOKING SPRAY

- 1/4 CUP UNBLEACHED, ALL-PURPOSE FLOUR
- 1/3 CUP WHOLE-WHEAT FLOUR
- 1/2 TEASPOON KOSHER SALT
- 3/4 TEASPOON BAKING SODA
- 1/2 TEASPOON GROUND CINNAMON
- 1/4 CUP ROLLED OATS (NOT INSTANT)
- 1/2 TEASPOON GRATED ORANGE ZEST
- 1/3 CUP WALNUTS, LIGHTLY TOASTED
- 2 LARGE CARROTS, PEELED AND CUT TO FIT FEED TUBE
- 1/3 CUP PACKED LIGHT BROWN SUGAR
- 2 LARGE EGGS, ROOM TEMPERATURE
- 1/3 CUP VEGETABLE OIL
- 1/2 TEASPOON PURE VANILLA EXTRACT
- 1/3 CUP SHREDDED, UNSWEETENED COCONUT
- 2 TABLESPOONS SUNFLOWER SEEDS

Makes 6 muffins

1. Preheat the oven to 350°F. Lightly coat a six-cup muffin pan with nonstick cooking spray. Reserve.
2. Put the flours, salt, baking soda, cinnamon, oats and zest into the large work bowl fitted with the large chopping blade. Process on High to sift, 10 seconds. Transfer ingredients to a medium mixing bowl; reserve.
3. Add the walnuts and pulse to chop, about 5 times. Leaving the nuts in the bowl, remove the chopping blade and insert the shredding disc with the medium setting facing up. Shred carrots. Add to the bowl with the dry ingredients. Stir to combine. Reserve.
4. Reinsert the large chopping blade and add the brown sugar, eggs, oil and vanilla extract to the work bowl and process until combined. Add the flour and carrot mixture and pulse to combine, about 3 times. Scrape down the sides of the bowl and add the coconut and sunflower seeds. Pulse to incorporate, about 3 to 4 times.
5. Divide the batter evenly among the prepared muffin cups and bake until a cake tester inserted into the center comes out clean, about 18 to 20 minutes.

Nutritional information per muffin:

*Calories 306 (60% from fat) • carb. 26g • pro. 6g • fat 21g
sat. fat 4g • chol. 62mg • sod. 372mg • calc. 27mg • fiber 3g*

BANANA NUT BREAD

Slice up this bread for a tasty breakfast on the go or for a sweet, afternoon snack.



	NONSTICK COOKING SPRAY
2	CUPS UNBLEACHED, ALL-PURPOSE FLOUR
2/3	CUP WALNUT HALVES, SHELLS REMOVED
1	TEASPOON BAKING POWDER
1	TEASPOON BAKING SODA
1/2	TEASPOON KOSHER SALT
2	RIPE BANANAS, CUT INTO 1-INCH PIECES
2	LARGE EGGS
2	LARGE EGG WHITES
1	CUP GRANULATED SUGAR
1/2	CUP PLAIN NONFAT YOGURT
4	TABLESPOONS UNSALTED BUTTER, CUT INTO 1-INCH PIECES AND ROOM TEMPERATURE
2	TEASPOONS PURE VANILLA EXTRACT

Makes one, 9-inch loaf

1. Preheat oven to 350°F. Lightly coat a 9-inch loaf pan with nonstick cooking spray. Reserve.
2. Put flour, nuts, baking powder, baking soda and salt into the large work bowl fitted with the large chopping blade. Pulse to combine, about 5 times. Transfer to a medium-size bowl and reserve.
3. Process banana on High until puréed, about 30 seconds. Scrape down the sides. Add eggs, egg whites, sugar, yogurt, butter and vanilla extract. Process on High until well combined, about 10 to 15 seconds. Add reserved dry ingredients. Pulse until flour is just mixed in, about 5 to 6 times.
4. Pour batter into prepared pan. Bake until golden brown and a toothpick inserted into the center comes out clean, about 50 minutes.
5. Cool in pan on a wire rack for 20 minutes. Remove from pan and cool completely.

Nutritional information per serving (1 slice based on 12 servings):

*Calories 227 (27% from fat) • carb. 37g • pro. 5g • fat 7g
sat. fat 3g • chol. 46mg • sod. 265mg • calc. 30mg • fiber 1g*

ZUCCHINI FRITTATA WITH MANCHEGO AND HAM

This frittata is hearty enough to feed a crowd.



- 8 LARGE EGGS, LIGHTLY BEATEN AND RESERVED IN A MEDIUM BOWL
- 1 SMALL LEEK, WASHED WELL, HALVED LENGTHWISE, WHITE AND LIGHT GREEN PARTS ONLY
- 1 SMALL ZUCCHINI, TRIMMED AND CUT TO FIT FEED TUBE
- 1 TABLESPOON EXTRA VIRGIN OLIVE OIL
- ½ TEASPOON KOSHER SALT, DIVIDED
- 4 OUNCES HAM SLAB
- 3 OUNCES MANCHEGO CHEESE
- ¼ TEASPOON FRESHLY GROUND BLACK PEPPER

Makes 8 servings

1. Preheat oven to 350°F. Insert dicing grid and blade. Dice leek and zucchini. Reserve in bowl.
2. Heat olive oil in a 10-inch nonstick skillet over medium-high heat. Once hot, add the diced leek, zucchini and ¼ teaspoon of the salt. Cook, stirring frequently, until zucchini is just tender, about 5 minutes.
3. While leek and zucchini are cooking, dice ham and add to bowl with the reserved eggs.
4. Remove dicing blade and grid. Insert the shredding disc with the fine setting facing up. Shred cheese. Put ½ of the cheese into the bowl with the eggs and ham. Add the remaining ¼ teaspoon salt and pepper. Stir. Reserve.
5. Reduce heat to medium and add egg mixture to the pan with the leek and zucchini. Stir constantly until eggs start to set, about 2 minutes. Let cook on stovetop until edges start to firm, about 5 minutes. Add remaining cheese to top of egg mixture.
6. Transfer to oven and cook until fully set, about 10 to 15 minutes.
7. Let cool slightly and serve warm.

Nutritional information per serving:

*Calories 140 (67% from fat) • carb. 4g • pro. 8g • fat 10g
sat. fat 4g • chol. 200mg • sod. 477mg • calc. 83mg • fiber 1g*

HOME FRIES

The dicing attachment makes it easier than ever to dice a lot of potatoes evenly — in this case, just in time for breakfast.



- 1 ONION, HALVED
- 1 LARGE GREEN BELL PEPPER, CUT TO FIT MEDIUM FEED TUBE AND SEEDED
- 2 TABLESPOONS EXTRA VIRGIN OLIVE OIL
- 4 RUSSET POTATOES (ABOUT 1 TO 1½ POUNDS), SCRUBBED
- 1 TEASPOON KOSHER SALT
- ½ TEASPOON SMOKED PAPIKA
- ¼ TEASPOON CHILI POWDER
- ¼ TEASPOON FRESHLY GROUND BLACK PEPPER

Makes about 4 cups

1. Insert the dicing grid and blade. Dice onion. Use cleaning tool to clean grid. Reserve in large work bowl. Dice pepper. Use cleaning tool to clean grid. Reserve with diced onion.
2. Heat olive oil in a large skillet over medium heat. When oil is hot, add the diced onion and pepper. Cook, stirring frequently, until soft and onion is translucent, about 5 minutes.
3. While onions and peppers are cooking, dice potatoes. Add to skillet with the salt, paprika, chili powder and black pepper; stir. Cover and cook until potatoes are fully cooked through, about 20 minutes.
4. Taste and adjust seasoning as desired. Serve immediately.

Nutritional information per serving (½ cup):

*Calories 72 (23% from fat) • carb. 12g • pro. 2g • fat 2g
sat. fat 0g • chol. 0mg • sod. 272mg • calc. 6mg • fiber 1g*

RUSTIC POTATO AND FENNEL TART

This recipe will quickly become a favorite when it comes to entertaining. It is easy to prepare and, since it's a free-form tart, the presentation cannot be beat.



½ RECIPE FLAKY PASTRY DOUGH,
PAGE 59

1 MEDIUM YUKON GOLD POTATO
(ABOUT 8 OUNCES)

¼ FENNEL BULB

¼ CUP DICED SPECK (PANCETTA OR
BACON CAN BE USED)

1 TABLESPOON EXTRA VIRGIN
OLIVE OIL

¼ TEASPOON KOSHER SALT

¼ TEASPOON GRATED LEMON ZEST

2 OUNCES GOAT CHEESE

EGG WASH (1 LARGE EGG
WHISKED WITH 1 TABLESPOON
OF WATER)

Makes one 9 to 10-inch tart

1. Have Flaky Pastry Dough prepared and ready to roll out. Preheat oven to 350°F. Line a baking sheet with parchment paper. Reserve.
2. Adjust the slicing disc to setting 2. Insert the slicing disc. Slice potatoes. Reserve in bowl.
3. Remove slicing disc and adjust to setting 4. Slice the fennel. Remove the slicing disc and stem.
4. Add the speck, olive oil, salt and lemon zest to the work bowl with the potatoes and fennel. Toss gently.
5. On a lightly dusted surface, roll Flaky Pastry Dough into a 12-inch circle, about ⅛-inch in thickness. Pile potato, fennel and speck mixture into the center of the dough. Top with dollops of goat cheese. Fold dough over mixture, leaving the center exposed. Brush dough with egg wash.
6. Bake until vegetables are tender and tart is golden brown, about 45 minutes to 1 hour. Cool on tray at least 10 to 15 minutes before cutting and serving.

Nutritional information per serving (based on 8 servings):

*Calories 229 (62% from fat) • carb. 17g • pro. 5g • fat 16g
sat. fat 10g • chol. 64mg • sod. 402mg • calc. 20mg • fiber 1g*

HUMMUS

Serve with warm pita for a satisfying snack. See tip on page 58 to learn how to make your own homemade pita using our pizza dough recipe.



- ¼ CUP FRESH ITALIAN PARSLEY LEAVES
- 1¼ TEASPOONS KOSHER SALT
- ½ TEASPOON GRATED LEMON ZEST
- 1 GARLIC CLOVE, PEELED
- 2 CANS (15.5 OUNCES EACH) CHICKPEAS, DRAINED AND RINSED
- ¼ CUP FRESH LEMON JUICE
- ¼ CUP WATER
- ¼ CUP EXTRA VIRGIN OLIVE OIL, PLUS 1 TABLESPOON FOR SERVING
- 2 TABLESPOONS TAHINI
- ½ TEASPOON GROUND CUMIN
- ⅛ TEASPOON PAPRIKA, OPTIONAL
- PINCH ZA'ATAR, OPTIONAL

Makes about 2½ cups

1. Put the parsley, salt, lemon zest and garlic into the large work bowl fitted with the large chopping blade. Pulse to roughly chop, about 5 to 6 times. Scrape down the sides of the bowl. Add remaining ingredients and process on High until smooth, about 5 minutes.
2. Taste and adjust seasoning as desired. Serve, drizzled with the extra tablespoon of olive oil and sprinkled with paprika and za'atar, if using.

Nutritional information per serving (1 tablespoon):

*Calories 43 (41% from fat) • carb. 5g • pro. 1g • fat 2g
sat. fat 0g • chol. 0mg • sod. 138mg • calc. 11mg • fiber 1g*

GUACAMOLE

A party favorite that can easily be tweaked to your preference.



- 1 GARLIC CLOVE, PEELED
- ½ TO 1 JALAPEÑO, SEEDED AND CUT INTO
- 1 1-INCH PIECES
- ½ SMALL ONION (RED OR WHITE)
- ¼ CUP PACKED CILANTRO LEAVES
- 5 RIPE AVOCADOS, PITTED AND FLESH SCOOPED OUT
- 2 TABLESPOONS FRESH LIME JUICE
- 1½ TEASPOONS KOSHER SALT, PLUS MORE IF DESIRED

Makes about 3 cups

1. Insert the large chopping blade into the large work bowl. With the food processor running on High, drop the garlic and jalapeño pieces through the small feed tube to finely chop. Add the onion and cilantro to the work bowl. Pulse to roughly chop, about 5 times.
2. Add the avocado, lime juice and salt. Pulse until desired consistency is achieved. Process on High if very smooth consistency is desired.
3. Taste and adjust seasoning as desired. Serve immediately or store in an airtight container in the refrigerator.

TIP: Press a piece of plastic wrap directly onto the surface of the finished guacamole to help prevent browning before serving or while storing.

Nutritional information per serving (¼ cup):

*Calories 137 (75% from fat) • carb. 8g • pro. 12g • fat 25g
sat. fat 2g • chol. 0mg • sod. 273mg • calc. 12mg • fiber 6g*

FIRE-ROASTED SALSA

The deep flavors of this restaurant-style salsa are addictive.



- 1 POUND RIPE TOMATOES,
QUARTERED
- 1 SMALL TO MEDIUM ONION,
QUARTERED
- ½ TO 1 JALAPEÑO, HALVED AND SEEDED
- 2 LARGE GARLIC CLOVES, PEELED
- 3 TABLESPOONS EXTRA VIRGIN OLIVE
OIL
- 2 TEASPOONS KOSHER SALT

Makes about 1½ cups

1. Line a baking sheet with aluminum foil. Put all of the ingredients onto the prepared baking sheet and toss. Broil on High until completely charred, about 40 to 50 minutes. Remove from oven and cool.
2. When vegetables are cool to touch, add all ingredients to the large bowl of the food processor fitted with the large chopping blade. Pulse until desired consistency is achieved, about 8 to 10 times for chunky.
3. Taste and adjust seasoning as desired. Serve with tortilla chips or alongside grilled meats.

Nutritional information per serving (¼ cup):

*Calories 80 (75% from fat) • carb. 4g • pro. 1g • fat 7g
sat. fat 1g • chol. 0mg • sod. 4mg • calc. 12mg • fiber 1g*

CRAB CAKES

Chopping all the mix-ins for crab cakes takes no time in the food processor.



- NONSTICK COOKING SPRAY
- 16** OUNCES LUMP CRABMEAT
- 1** GARLIC CLOVE
- 1** RED BELL PEPPER, SEEDED AND CUT INTO **2**-INCH PIECES
- 3** GREEN ONIONS, CUT INTO **1**-INCH PIECES
- ½** CUP FRESH PARSLEY LEAVES, LOOSELY PACKED
- 1** TEASPOON EXTRA VIRGIN OLIVE OIL
- ¼** TEASPOON KOSHER SALT
- ¼** TEASPOON FRESHLY GROUND BLACK PEPPER
- 2** LARGE EGGS, LIGHTLY BEATEN
- 1** CUP BREADCRUMBS, SEE PAGE **20** FOR RECIPE
- ½** CUP MAYONNAISE
- 1** TEASPOON WORCESTERSHIRE SAUCE
- 1½** TEASPOONS SEAFOOD SEASONING
- 2** TEASPOONS DIJON MUSTARD HOT SAUCE, OPTIONAL
- TARTAR SAUCE, FOR SERVING
- LEMON WEDGES, FOR SERVING

Makes 12 crab cakes

1. Pick through crabmeat to make sure there are no shells; reserve in refrigerator. Preheat oven to 400°F. Line a baking sheet with aluminum foil. Spray with nonstick cooking spray. Set aside.
2. Insert the small chopping blade into small work bowl. With the food processor running on High, drop the garlic through the small feed tube to finely chop. Add the pepper, green onions and parsley and pulse to coarsely chop, about 10 to 12 times.
3. Put the oil into a large skillet set placed over medium heat. Cook chopped vegetables with salt and pepper until soft, about 5 to 7 minutes. Remove and reserve in a large mixing bowl.
4. Once vegetables have cooled slightly, add the crab, eggs, breadcrumbs, mayonnaise, Worcestershire, seafood seasoning, mustard and a dash or two of the hot sauce, if using, to the mixing bowl. Mix thoroughly but carefully by hand, so not to break up the crabmeat too much.
5. Form crabmeat mixture into 8 round cakes. Place on prepared baking sheet and bake until crab cakes are evenly golden on each side, about 8 to 10 minutes per side.
6. Serve immediately with prepared tartar sauce if desired, and with a lemon wedge.

Nutritional information per crab cake:

Calories 186 (57% from fat) • carb. 12g • pro. 8g • fat 12g
sat. fat 2g • chol. 87mg • sod. 652mg • calc. 128mg • fiber 0g

POTATO NACHOS

Thinly sliced potatoes make a heartier, delicious base for nachos.



- 2** POUNDS RUSSET POTATOES
- 1** TABLESPOON EXTRA VIRGIN OLIVE OIL
- 1** TEASPOON KOSHER SALT
- 1** BUNCH GREEN ONIONS, TRIMMED
- ½ TO 1** WHOLE JALAPEÑO, HALVED LENGTHWISE AND SEEDED
- 1** CAN (15 OUNCES) WHOLE BLACK PITTED OLIVES
- 8** OUNCES CHEESE, SUCH AS SHARP CHEDDAR
- SALSA, GUACAMOLE AND SOUR CREAM, FOR SERVING

Makes 8 servings

1. Preheat oven to 425°F. Line two baking sheets with aluminum foil. Reserve.
2. Adjust the slicing disc to setting 3. Insert the slicing disc. Slice potatoes. Remove slicing disc and stem. Toss potatoes with olive oil and salt.
3. Spread potatoes onto the baking sheets in a single layer. Bake until golden brown and crispy, about 45 minutes.
4. While potatoes are baking, reinsert stem and slicing disc (still at setting 3). Slice the green onions, jalapeño and olives. Remove from bowl and reserve.
5. Insert shredding disc with the medium setting facing up. Shred cheese. Reserve in bowl.
6. When potatoes are done baking, remove from oven and let cool slightly. Pile half of the potatoes into the center of one baking sheet. Sprinkle with half of the green onions, jalapeño, olives and cheese. Pile the remaining potatoes on top of the first layer and sprinkle with remaining ingredients. Bake until cheese is melted and slightly browned, about 5 minutes.
7. Serve immediately with chunky salsa, guacamole and sour cream if desired.

Nutritional information per serving:

*Calories 225 (83% from fat) • carb. 4g • pro. 6g • fat 21g
sat. fat 7g • chol. 30mg • sod. 883mg • calc. 202mg • fiber 21g*

WHITE SANGRIA

The Cuisinart® dicing attachment cuts fruit into perfect bite-sized pieces for sangria; best part is, the prep takes no time!



- 1 BOTTLE (750 ML) DRY WHITE WINE SUCH AS CHARDONNAY
- 1/3 CUP ORANGE-FLAVORED LIQUEUR
- 1 CUP WHOLE STRAWBERRIES, HULLED
- 1 SMALL PEACH, PITTED
- 1/2 MANGO, PEELED AND PITTED
- 1 SMALL APPLE, HALVED AND CORED

Makes about 5 servings

1. In a large pitcher or glass serving bowl, combine the wine and Grand Marnier®. Reserve.
2. Insert the dicing grid and blade. Dice the fruit. Add to the wine mixture. If time allows, let sit overnight so the flavors can develop.
3. Serve cold.

Nutritional information per serving (about 5 ounces):

*Calories 174 (11% from fat) • carb. 17g • pro. 1g • fat 0g
sat. fat 0g • chol. 0mg • sod. 27mg • calc. 11mg • fiber 2g*

CREAMY WHITE BEAN SOUP

This soup tastes even better the next day, when the flavors are given more time to develop.



- 3 OUNCES DICED PANCETTA
- 3 SMALL CARROTS, PEELED AND CUT INTO 1-INCH PIECES
- 2 SMALL STALKS CELERY, CUT INTO 1-INCH PIECES
- 1 SMALL ONION, CUT INTO 1-INCH PIECES
- 1 FRESH THYME SPRIG
- 1 GARLIC CLOVE, PEELED
- ¼ TEASPOON FRESHLY GROUND BLACK PEPPER, PLUS MORE TO TASTE
- 3 CANS (15.5 OUNCES EACH) CANNELLINI BEANS, WITH CANNING LIQUID
- 2 TO 3 CUPS WATER, OR LOW-SODIUM CHICKEN BROTH FOR DEEPER TASTE
- KOSHER SALT TO TASTE

Makes about 8 cups

1. Put a large stockpot over medium heat. Once hot, add pancetta and cook slowly, stirring frequently, to render fat, about 5 minutes.
2. While pancetta is rendering, put carrots, celery and onion into the large work bowl fitted with the large chopping blade. Pulse to roughly chop, about 10 times. Add chopped carrots, celery and onion to the stockpot with the pancetta, stir. Add thyme, garlic and black pepper. Allow to cook to soften, about 3 minutes.
3. Add beans with the liquid to the pot, plus enough liquid (water or low-sodium chicken broth) to just cover beans, about 2½ cups. Bring soup to a boil, cover with lid, reduce to a simmer and cook until the beans and vegetables are very tender, about 25 to 30 minutes. Remove from heat and let cool 5 minutes. Remove thyme sprig.
4. Add soup to work bowl and process on High until desired consistency is achieved, 30 seconds to 1 minute 30 seconds.
5. Taste and season with salt to taste, one pinch at a time.

TIP: Do not over season. Flavors will deepen as soup cools; best enjoyed warm.

Nutritional information per serving (1 cup):

Calories 177 (24% from fat) • carb. 24g • pro. 10g • fat 5g
sat. fat 1g • chol. 11mg • sod. 264mg • calc. 62mg • fiber 7g

SPRING VEGETABLE MINISTRONE WITH PESTO

This recipe contains many ingredients and requires a lot of preparation, but the dicing attachment makes it much easier than dicing by hand — and we promise the final result is worth it!



MAKES ABOUT 14 CUPS

- 1 SMALL LEEK, WASHED WELL AND TRIMMED, WHITE AND LIGHT GREEN PARTS ONLY
- 1 SMALL CELERY STALK, TRIMMED AND CUT TO FIT FEED TUBE
- 6 OUNCES GREEN BEANS, TRIMMED
- 1 SMALL ZUCCHINI, TRIMMED AND CUT TO FIT FEED TUBE
- 1 SMALL YELLOW SQUASH, TRIMMED AND CUT TO FIT FEED TUBE
- ½ SMALL FENNEL BULB, TRIMMED, CORED AND CUT TO FIT FEED TUBE
- 4 MEDIUM CARROTS, PEELED AND TRIMMED TO FIT FEED TUBE
- 6 OUNCES RED POTATOES
- 1½ TEASPOONS EXTRA VIRGIN OLIVE OIL
- 1 GARLIC CLOVE, SMASHED AND PEELED
- ¾ TEASPOON KOSHER SALT, DIVIDED
- ½ TEASPOON FRESHLY GROUND BLACK PEPPER, DIVIDED
- 6 CUPS CHICKEN OR VEGETABLE BROTH
- 1 3- TO 4-INCH PARMESAN RIND
- 1 CAN (15 OUNCES) CHICKPEAS, DRAINED AND RINSED
- 1 CAN (15 OUNCES) RED KIDNEY BEANS, DRAINED AND RINSED
- 2 CUPS COOKED DITALINI PASTA, OPTIONAL

PESTO:

MAKES ABOUT ¾ CUP

- 1 SMALL GARLIC CLOVE
- 3 CUPS PACKED FRESH BASIL LEAVES
- 1¼ TEASPOONS KOSHER SALT
- ¼ TEASPOON FRESHLY GROUND BLACK PEPPER
- ½ TO ⅔ CUP EXTRA VIRGIN OLIVE OIL

1. Prepare all ingredients before beginning recipe. Using the slicing disc first, slice the leek and celery on setting 5. Reserve together. Adjust slicing disc to setting 7. Slice green beans. Reserve.
2. Replace the disc with the dicing grid and blade. Dice zucchini and yellow squash. Reserve together. Dice fennel and carrots. Reserve together. Have potatoes ready to dice.
3. Put olive oil in a large stockpot over medium heat. Once the oil is hot, add the reserved leek, celery, carrots, fennel with the garlic and ¼ teaspoon of salt and a pinch of the pepper. Sweat until vegetables are slightly soft, about 10 minutes.
4. While the vegetables are sweating, dice the potatoes. Stir into the pot along with the green beans and the remaining salt and pepper. Stir well.
5. Add the broth and Parmesan rind. Increase the heat and bring the liquid to a boil. Add the zucchini, squash, chickpeas and beans. Reduce heat to maintain a simmer until all the vegetables are tender, about 20 to 30 minutes. If using the ditalini, stir in during the last 5 to 10 minutes to heat through.
6. While soup is simmering, prepare the pesto in the small bowl fitted with the small chopping blade: With the food processor running on High, drop the garlic through the small feed tube to finely chop. Scrape down the bowl and add basil, salt and pepper. Pulse to roughly chop, about 5 to 6 times. Run food processor on High and drizzle in oil through the small feed tube. Process until combined, about 1 minute.
7. Once the soup has simmered and all vegetables are tender, taste and adjust seasoning as desired.
8. Serve in individual bowls topped with a dollop of pesto. Pesto is best stirred into soup before eating.

Nutritional information per serving (1 cup):

*Calories 115 (18% from fat) • carb. 18g • pro. 6g • fat 2g
sat. fat 0g • chol. 0mg • sod. 568mg • calc. 62mg • fiber 4g*

PEAR AND KALE SALAD

This salad pairs well with our Basic Vinaigrette on page 27.



- 1 BUNCH LACINATO KALE
- 1/4 SMALL RED CABBAGE HEAD,
CORED AND CUT TO FIT FEED TUBE
- 2 CARROTS, PEELED AND CUT TO FIT
FEED TUBE
- 1 PEAR, CORED AND QUARTERED
- 1/2 ENGLISH CUCUMBER, QUARTERED
AND CUT TO FIT FEED TUBE
- 1/2 CUP WALNUTS, TOASTED

Makes 9 to 10 cups

1. Set slicing disc to setting 7. Insert slicing disc. Slice kale. Reserve in bowl.
2. Adjust slicing disc to setting 2. Slice cabbage, carrots, pear and cucumber. Transfer to a large bowl. Add walnuts. Toss with desired dressing.

TIP: The dressing for this salad (and most others) can be made in the large bowl with all the veggies sliced right on top for the ultimate one-bowl cleanup.

Nutritional information per serving (1 cup):

*Calories 38 (24% from fat) • carb. 7g • pro. 1g • fat 1g
sat. fat 0g • chol. 0mg • sod. 77mg • calc. 38mg • fiber 2g*

CELERY ROOT SALAD WITH TARRAGON DRESSING

This salad gets better the longer you let it sit; the flavors become bolder and the celery root gets softer. Make up to a couple of days ahead to serve at a party or make to eat all week.



DRESSING:

MAKES 1 CUP

- 1 SMALL SHALLOT, CUT INTO 1/2-INCH PIECES
- 1/4 CUP PACKED FRESH TARRAGON LEAVES
- 1/4 CUP APPLE CIDER VINEGAR
- 1 TEASPOON FRESH LEMON JUICE
- 1 TEASPOON DIJON MUSTARD
- 3/4 TEASPOON KOSHER SALT
- 1/4 TEASPOON FRESHLY GROUND BLACK PEPPER
- 3/4 CUP EXTRA VIRGIN OLIVE OIL

SALAD:

MAKES ABOUT 8 CUPS

- 1 CUP RAW, UNSALTED PISTACHIOS, SHELLED
- 2 SMALL HEADS OR 1 LARGE HEAD (ABOUT 12 OUNCES) CELERY ROOT
- 1/2 LEMON (FOR RUBBING CELERY ROOT AND APPLE)
- 2 TEASPOONS FRESH LEMON JUICE, DIVIDED
- 1 GALA (OR SIMILAR) APPLE, CORED
- 1/2 CUP GOLDEN RAISINS
- 1/2 CUP TARRAGON DRESSING
- CHOPPED TARRAGON, FOR GARNISH

1. To make dressing: Put the shallot and tarragon into the small work bowl fitted with the small chopping blade. Pulse to roughly chop, about 2 to 3 times.
2. Add the vinegar, lemon juice, mustard, salt and pepper to work bowl. Process on Low to fully blend, about 20 seconds.
3. While food processor is running on Low, slowly pour the olive oil through the drizzle hole in the pusher. Continue to process on Low until emulsified, about 40 seconds. Reserve or store in an airtight container in the refrigerator.
4. To make salad: Put the pistachios into the large bowl fitted with the large chopping blade. Pulse, to roughly chop, about 5 to 6 times. Reserve in bowl.
5. Remove the large chopping blade and insert the shredding disc with the medium side facing up. Prep celery root by washing and peeling. Rub peeled celery root with lemon half. Cut celery root into pieces so that they will fit into the feed tube. Rub each piece with more lemon. Shred celery root on High. Transfer to a large mixing bowl. Toss with 1 teaspoon lemon juice.
6. Prep apple by halving, coring and rubbing with lemon half. Remove medium shredding disc and flip so the fine side is facing up; shred apple on High. Add to bowl with celery root. Toss mixture with additional teaspoon of lemon juice.
7. Add raisins and Tarragon Dressing; toss to coat. Sprinkle with chopped pistachios and more fresh tarragon if desired.

Nutritional information for dressing per serving (2 tablespoons):

Calories 186 (97% from fat) • carb. 1g • pro. 0g • fat 21g
sat. fat 3g • chol. 0mg • sod. 222mg • calc. 6mg • fiber 0g

Nutritional information for salad per serving (1 cup):

Calories 147 (40% from fat) • carb. 20g • pro. 4g • fat 7g
sat. fat 1g • chol. 0mg • sod. 45mg • calc. 44mg • fiber 4g

POTATO SALAD

The dicing attachment creates the perfect sized pieces for potato salad.



- 2 POUNDS RED POTATOES, SCRUBBED
- ¼ CUP FRESH ITALIAN PARSLEY LEAVES, LOOSELY PACKED
- ½ SMALL RED ONION, CUT INTO 1-INCH PIECES
- 3 CELERY STALKS, CUT INTO 1-INCH PIECES
- 3 TABLESPOONS EXTRA VIRGIN OLIVE OIL
- 2 TABLESPOONS WHOLE GRAIN DIJON MUSTARD
- 1 TABLESPOON WHITE WINE VINEGAR
- 1½ TO 2 TEASPOONS KOSHER SALT
- ¼ TEASPOON FRESHLY GROUND BLACK PEPPER

Makes about 5 cups

1. Insert the dicing grid and blade. Dice potatoes. Put into a large cooking pot. Add water to 1 inch above the potatoes. Boil until tender. Drain, rinse with cold water and drain again and let cool.
2. While potatoes are cooking, put parsley, onion and celery into the small work bowl fitted with the small chopping blade. Pulse to roughly chop, about 3 to 4 times.
3. When potatoes are cooked and slightly cool, transfer to a large bowl. Add chopped parsley, onion and celery mixture to the bowl with the potatoes. Add the remaining ingredients. Stir gently.
4. Taste and adjust seasoning as desired.

Nutritional information for salad per serving (½ cup):

*Calories 92 (34% from fat) • carb. 13g • pro. 2g • fat 3g
sat. fat 0g • chol. 0mg • sod. 364mg • calc. 13mg • fiber 2g*

POTATO PANCAKES

This no-fail recipe is great for the holidays, or any time of the year.



- 2 TABLESPOONS FRESH ITALIAN PARSLEY LEAVES
 - 1 POUND RUSSET POTATOES*, PEELED AND CUT TO FIT FEED TUBE
 - ½ SMALL ONION, TRIMMED
 - 2 TABLESPOONS UNBLEACHED ALL-PURPOSE FLOUR (YOU MAY USE MATZO MEAL)
 - 1 TEASPOON KOSHER SALT
 - ¼ TEASPOON FRESHLY GROUND BLACK PEPPER
 - 1 LARGE EGG, LIGHTLY BEATEN
 - 4 TABLESPOONS EXTRA VIRGIN OLIVE OIL, DIVIDED
- * ½ POUND RUSSET, ½ POUND SWEET POTATO MAY BE USED

Makes twelve, 3-inch pancakes

1. Insert the small bowl with the small chopping blade. Put parsley in the bowl and process on High to chop evenly. Reserve.
2. Insert the shredding disc with the fine side facing up. Shred the potato and the onion. Transfer to a clean towel and gently wring to squeeze out all of the excess liquid. Transfer to a large bowl. Add reserved parsley, flour, salt and pepper; toss to mix thoroughly. Add egg and stir.
3. Divide the potato mixture evenly to make 12 pancakes. Form into balls and then flatten into pancakes.
4. Put 2 tablespoons of the oil into a large skillet and heat over medium high heat. Once hot, add 6 of the pancakes and cook until golden brown, about 3 to 4 minutes. Flip and cook on the other sides until also golden brown and cooked thoroughly, about 5 to 6 minutes, lowering the heat if necessary to cook through and not burn.
5. Transfer to a plate lined with a paper towel to absorb excess grease. Add the remaining 2 tablespoons of oil to the pan and heat to cook second batch of pancakes.
6. Serve immediately with applesauce or sour cream if desired.

Nutritional information per serving (1 latke):

*Calories 83 (53% from fat) • carb. 8g • pro. 2g • fat 5g
sat. fat 1g • chol. 18mg • sod. 8mg • calc. 9mg • fiber 1g*

FALAFEL

Serve with pita bread, hummus, chopped tomatoes, cucumbers and onions.



- 1 CUP DRIED GARBANZO BEANS,
SOAKED IN COLD WATER OVERNIGHT
- 1 GARLIC CLOVE, PEELED
- 1/2 SMALL ONION, CUT INTO
1-INCH PIECES
- 1 TEASPOON KOSHER SALT
- 1/4 TEASPOON FRESHLY GROUND
BLACK PEPPER
- 1 TEASPOON GROUND CUMIN
- 3/4 TEASPOON GROUND CORIANDER
- 1/4 CUP FRESH ITALIAN PARSLEY
LEAVES, LOOSELY PACKED
- 1/4 TEASPOON BAKING SODA
- 1 TABLESPOON WATER
- 1/4 CUP VEGETABLE OIL

Makes 8 falafel

1. Drain the soaked garbanzo beans. Put the drained beans into the large work bowl fitted with the large chopping blade. Pulse to break up and then process on High until smooth, about 30 seconds. Add the garlic, onion, salt, pepper, cumin and coriander to the beans and process until the vegetables are finely chopped. Pulse in the parsley.
2. Dissolve the baking soda in the water and reserve. With the machine running on High, add the baking soda and water and continue to process until the falafel batter is smooth.
3. Form patties using a 1/4-cup measuring cup.
4. Fry until deeply and evenly golden.
Serve immediately.

Nutritional information per falafel:

Calories 96 (15% from fat) • carb. 16g • pro. 5g • fat 2g
sat. fat 0g • chol. 0mg • sod. 314mg • calc. 34mg • fiber 5g

CHICKEN BURGERS WITH MANGO-AVOCADO SALSA

Remaining salsa can be served with tortilla chips—you're not going to want one bite to go to waste.



CHICKEN BURGERS:

- 2 POUNDS BONELESS SKINLESS CHICKEN THIGHS, CUT INTO 1-INCH PIECES
- 1 ½ TEASPOONS KOSHER SALT
- ½ TEASPOON FRESHLY GROUND BLACK PEPPER
- 3 GREEN ONIONS, TRIMMED AND CUT INTO 1-INCH PIECES
- ½-1 JALAPENO, SEEDED AND CUT INTO 1-INCH PIECES

SALSA:

- ¼ CUP FRESH CILANTRO LEAVES, LOOSELY PACKED
- 2 AVOCADOS, HALVED, PITTED AND SCOOPED OUT
- 1 MANGO, PEELED, HALVED AND PITTED
- 1 TEASPOON KOSHER SALT
- 1-2 TEASPOONS FRESH LIME JUICE
- 1 TABLESPOON VEGETABLE OIL

Makes 6 burgers; 3 cups of salsa

1. Put cut chicken thigh pieces into the freezer for 30 minutes to slightly harden.
2. While thighs in are in freezer, prepare salsa: Insert the large chopping blade into the large work bowl. With the food processor running on high, drop the jalapeño pieces through the small feed tube to finely chop. Add the cilantro and pulse to roughly chop, about 6 times. Remove the large blade and insert the dicing grid and blade. Dice the avocados, followed by the mango. Remove the dicing grid and add the salt and lime juice to the mixture. Gently fold and transfer to a medium bowl. Taste and adjust seasoning as desired. Cover with plastic wrap and store in the refrigerator until ready to use.
3. Wipe down the large work bowl. Re-insert the large blade and put green onions into the bowl. Pulse to roughly chop, about 6 times. Once 30 minutes have elapsed and the chicken pieces are slightly firm but not hard, add the chicken thighs to the bowl. Add the salt and pepper. Pulse until medium fine, about 16 times. Form into 6 even patties.
4. To cook chicken patties, preheat oven to 350°F. Heat oil in a large nonstick pan. Once oil is hot, add 3 of the chicken patties, being careful not to crowd the pan. Brown each side until a nice, golden brown crust forms, then transfer to a baking sheet. Repeat with remaining patties and finish cooking in the oven until the internal temperature reaches 165°F. Remove from oven and let stand for 5 minutes.
5. Serve, topped with mango-avocado salsa and a lime wedge. May also be served on a soft bun like brioche or potato.

Nutritional information per serving (1 burger with ½ cup salsa):

Calories 316 (45% from fat) • carb. 12g • pro. 32g • fat 16g
sat. fat 3g • chol. 125mg • sod. 1026mg • calc. 36mg • fiber

MEATBALLS

This recipe allows you to chop and mix all of the ingredients directly in the Cuisinart® food processor.



- 1½** POUNDS BEEF CHUCK, CUT INTO 1-INCH PIECES
- ½** POUND PORK SHOULDER, TRIMMED OF ANY EXCESS FAT, CUT INTO 1-INCH PIECES
- 2** GARLIC CLOVES, PEELED
- ½** CUP FRESH ITALIAN PARSLEY LEAVES, LOOSELY PACKED
- ½** ONION, CUT INTO 1-INCH PIECES
- ½** CUP ITALIAN SEASONED BREADCRUMBS
- 1½** TEASPOONS KOSHER SALT **2** LARGE EGGS, LIGHTLY BEATEN

Makes 18 meatballs

1. Put beef and pork pieces into the freezer for 30 minutes to slightly harden. Preheat oven to 425° F. Line two baking sheets with aluminum foil. Reserve.
2. While meat is in freezer, insert the large chopping blade into the large work bowl. With the food processor running on High, drop the garlic through the small feed tube to finely chop. Add the parsley and onion to the bowl and pulse to roughly chop, about 5 to 6 times. Once the 30 minutes have elapsed and the meat is firm but not hard, add the meat to the work bowl. Add the breadcrumbs, salt and eggs. Pulse to chop meat and combine ingredients until meat is medium fine, about 35 times.
3. Using a ¼ cup measuring cup, form meat mixture into balls. Bake until golden brown on all sides, about 25 to 30 minutes.
4. Serve, plain or with tomato sauce.

Nutritional information per meatball:

*Calories 119 (46% from fat) • carb. 3g • pro. 13g • fat 6g
sat. fat 2g • chol. 60mg • sod. 324mg • calc. 17mg • fiber 0g*

PINEAPPLE FRIED RICE

Try making this recipe with cauliflower—yes, cauliflower!—instead of rice. See our tip below on how to prepare.



- 1 GARLIC CLOVE, PEELED
- 1 1-INCH PIECE FRESH GINGER, PEELED AND HALVED
- 1 SMALL ONION, TRIMMED AND HALVED
- 2 MEDIUM CARROTS, PEELED AND CUT TO FIT FEED TUBE
- ½ PINEAPPLE, CORED
- ¼ CUP GRAPESEED OIL, DIVIDED
- 4 CUPS COOKED AND COOLED JASMINE RICE OR 4 CUPS PULSED CAULIFLOWER* (FROM ABOUT 1 POUND CAULIFLOWER)
- 1 CUP CASHEWS (TOASTED)
- 1 TEASPOON KOSHER SALT, PLUS MORE TO TASTE
- ¼ TEASPOON GROUND TURMERIC
- 2 LARGE EGGS, LIGHTLY BEATEN
- 2 TABLESPOONS SOY SAUCE, REDUCED SODIUM
- 1 TEASPOON FISH SAUCE
- 2 GREEN ONIONS, TRIMMED AND THINLY SLICED (WHITE AND GREEN PARTS)
- 1 TABLESPOON SAKE (OR OTHER WHITE WINE)

Makes 5 ½ cups

1. Insert the large chopping blade into the large workbowl. With the food processor running on High, drop the garlic and ginger through the small feed tube to finely chop. Remove the chopping blade and insert the dicing grid and blade. Dice the onion and carrots. Remove and reserve. Dice the pineapple. Remove and reserve separately.
2. Put 2 tablespoons of the oil into a large nonstick skillet set over medium heat. Once hot, add the garlic, ginger, onion and carrots. Sauté until vegetables are softened, about 5 minutes. Add the remaining oil and allow to heat for about 1 minute.
3. Add the rice (or cauliflower “rice” if using) and cashews. Cook, allowing it to sit for 1 to 2 minutes between stirs, until crisped and slightly browned, 6 to 8 minutes. Add the pineapple, salt and turmeric; stir, scraping up brown bits from bottom of pan.
4. Push mixture to one side of the pan. Add eggs and let cover half of the pan, and cook, breaking up with a spatula while cooking. Once eggs have cooked, mix with rice.
5. Reduce heat to low. Stir in soy sauce, fish sauce and green onions. Taste, adding additional salt if desired. Add the sake to deglaze the pan, scraping up brown bits from bottom of the pan. Serve immediately.

***TIP:** The rice can be substituted with cauliflower. Simply cut into florets and put into the large work bowl fitted with the large chopping blade. Pulse to break up, then run on High to finely and evenly chop. Cauliflower will cook when added to the pan in place of the rice.

Nutritional information per serving (based on 1 cup with rice):

Calories 618 (61% from fat) • carb. 101g • pro. 12g • fat 19g
sat. fat 3g • chol. 53mg • sod. 490mg • calc. 35mg • fiber 2g

Nutritional information per serving (based on 1 cup with cauliflower “rice”):

Calories 787 (68% from fat) • carb. 128g • pro. 16g • fat 25g
sat. fat 4g • chol. 68mg • sod. 623mg • calc. 45mg • fiber 3g

RATATOUILLE

Make this summer stew when vegetables are abundant in the garden.



- 2 ZUCCHINI, ABOUT 1 POUND
- 1 EGGPLANT, ABOUT 1 POUND
- 1 ONION, TRIMMED AND HALVED
- 2 TABLESPOONS OLIVE OIL
- 1 GARLIC CLOVE, SMASHED AND PEELED
- 2 TABLESPOONS TOMATO PASTE
- 1½ POUNDS PLUM TOMATOES
- 1¼ TEASPOONS KOSHER SALT
- ¼ TEASPOON FRESHLY GROUND BLACK PEPPER
- ½ TEASPOON DRIED OREGANO
- 1 SPRIG FRESH THYME
- 10 FRESH BASIL LEAVES, THINLY SLICED

Makes about 6 cups

1. Insert the dicing grid and blade. Dice zucchini, eggplant and onion. Use cleaning tool to clean grid. Reserve in bowl.
2. Put the olive oil and garlic clove in a large saucepan set over medium-high heat. Once the oil is hot, add the reserved diced vegetables. Stir to coat and allow to cook until slightly browned and tender about 5 to 6 minutes.
3. While the zucchini, eggplant and onion are cooking, dice plum tomatoes. Reserve in bowl.
4. Add tomato paste to the pan with the cooking vegetables; stir and cook 1 to 2 minutes.
5. Add plum tomatoes, salt, pepper, oregano and thyme sprig; stir. Cover and reduce heat to medium and cook until tender, about 10 minutes. Remove lid and cook until liquid is reduced and slightly thickened, about 5 minutes. Remove from heat and stir in fresh basil. Taste and adjust seasoning as desired. Serve hot.

Nutritional information per serving (1 cup):

*Calories 176 (41% from fat) • carb. 14g • pro. 3g • fat 5g
sat. fat 1g • chol. 0mg • sod. 473mg • calc. 36mg • fiber 6g*

BRUSSELS SPROUTS WITH LARDONS

Slicing the Brussels sprouts (and any other ingredient) in the food processor ensures they will all cook evenly.



- 1 POUND BRUSSELS SPROUTS,
CLEANED AND ROOT END TRIMMED
- ½ POUND SLAB BACON, CUT INTO
LARDONS (¼-INCH CUBES)
- 2 TABLESPOONS APPLE CIDER
VINEGAR
- KOSHER SALT AND BLACK PEPPER
FOR SEASONING, IF DESIRED

Makes 3 cups

1. Adjust the slicing disc to setting 5. Insert slicing disc. Slice Brussels sprouts. Reserve in work bowl.
2. Put bacon lardons into a large nonstick skillet set over medium heat. Cook until crispy, stirring often to prevent sticking, about 6 minutes.
3. Use a slotted spoon to remove bacon and transfer to a plate. Leaving the bacon fat in the pan, increase the heat to medium-high. When hot, add reserved Brussels sprouts and cook until brown on one side, 3 to 4 minutes. Stir and cook until tender, an additional 1 to 2 minutes. Add in lardons and vinegar; stir. Remove from heat.
4. Taste and season with salt and pepper if desired.

Nutritional information per serving (½ cup):

Calories 222 (65% from fat) • carb. 7g • pro. 13g • fat 16g
sat. fat 5g • chol. 41mg • sod. 802mg • calc. 32mg • fiber 3g

CAULIFLOWER-CRUST PIZZA

Try this cauliflower crust as a gluten-free alternative.



CRUST*:

- 1 HEAD (ABOUT 1 POUND)
CAULIFLOWER, FLORETS ONLY
- 2 LARGE EGGS
- $\frac{3}{4}$ CUP GRATED PARMESAN CHEESE
- $\frac{1}{2}$ TEASPOON KOSHER SALT
- $\frac{1}{4}$ TEASPOON FRESHLY GROUND
BLACK PEPPER
- $\frac{1}{4}$ TEASPOON ONION POWDER
- $\frac{1}{4}$ TEASPOON GARLIC POWDER

TOPPING:

- $\frac{1}{2}$ BELL PEPPER, SEEDED AND CUT
TO FIT FEED TUBE
- $\frac{1}{2}$ ONION, TRIMMED
- 3 WHITE MUSHROOMS
- $\frac{1}{2}$ POUND MOZZARELLA,
REFRIGERATED
- $\frac{3}{4}$ CUP PIZZA SAUCE, SEE RECIPE
PAGE 23
- 2 TABLESPOONS EXTRA VIRGIN
OLIVE OIL

Makes 8 servings

1. Preheat oven to 450°F. Line a baking sheet with parchment paper. Set aside.
2. Put cauliflower florets into the large work bowl fitted with the large chopping blade. Pulse to break up, 5 to 6 times, and then process on High to finely chop, about 30 seconds. Add remaining crust ingredients to work bowl and process on High again to combine, about 30 seconds. Transfer ingredients to the prepared baking sheet. Form into a rectangle about $\frac{1}{2}$ inch thick. Bake until golden brown and slightly firm, about 40 minutes. Cool slightly.
3. While cauliflower is cooling, adjust slicing disc to setting 5. Insert slicing disc. Slice pepper, onion and mushrooms. Transfer to a large bowl. Reserve.
4. Insert shredding disc with the medium setting facing up. Shred the mozzarella. Reserve in bowl.
5. Put the pizza sauce in the center of the cooled cauliflower crust and spread evenly, leaving a 1-inch border. Spread vegetables evenly over sauce. Spread cheese evenly over vegetables. Brush edges of crust with olive oil.
6. Bake until toppings are soft and cheese is melted and bubbly, about 15 to 20 minutes.

*Our Pizza Dough recipe on page 58 can also be used. Unlike the cauliflower crust, it does not need to be prebaked first. To make: On a lightly dusted surface, roll out pizza dough into a 12-inch circle. Transfer pizza dough to a pizza screen sprayed with nonstick cooking spray or a baking sheet dusted very well with cornmeal. Top with sauce and toppings, brush edges of crust with olive oil and bake until crust is golden brown, toppings are soft and cheese is melted and bubbly.

Nutritional information per serving:

Calories 210 (60% from fat) • carb. 8g • pro. 15g • fat 15g
sat. fat 7g • chol. 80mg • sod. 715mg • calc. 366mg • fiber 2g

SAUSAGE ROLLS

The taste of homemade sausage surpasses the taste of prepackaged and is very easy to make in the Cuisinart® food processor. Cook it “loose” on the stovetop to add to any pasta or sauce dish, or make New York City-style sausage rolls using pizza dough and sauce like we do here.



- 1 POUND PORK SHOULDER, TRIMMED OF ANY EXCESS FAT AND CUT INTO 1-INCH PIECES
- 1 TEASPOON FENNEL SEEDS
- 1 GARLIC CLOVE, PEELED
- 1½ TEASPOONS KOSHER SALT
- ½ TEASPOON FRESHLY GROUND BLACK PEPPER
- ¼ TEASPOON GRANULATED SUGAR
- 1 RECIPE PIZZA DOUGH, PAGE 58
- 2 CUPS SHREDDED MOZZARELLA CHEESE
- 1 CUP PREPARED PIZZA SAUCE (OR USE RECIPE ON PAGE 23)

Makes four, 7-inch rolls

1. Put pork pieces into the freezer for 30 minutes to slightly harden. While pork is in the freezer, toast fennel seeds in a pan over medium heat. Reserve.
2. Insert the large chopping blade into the large work bowl. With the food processor running on High, drop the garlic through the small feed tube to finely chop. When the pork shoulder cubes are sufficiently cold, put them into the large bowl with the chopped garlic. Add the toasted fennel seeds, salt, pepper and sugar. Pulse to coarsely chop, about 15 to 20 times.
3. In a large skillet set over medium-high heat, cook chopped pork until completely browned. With a slotted spoon, transfer to a plate lined with a paper towel to drain and cool. Preheat oven to 425°F.
4. While sausage is cooling and oven is heating, lightly dust a flat surface with flour. Roll the prepared pizza dough into an 18-inch circle. Divide into four equal pieces.
5. Take one piece of dough and place it in front of you with the point facing away from you. Put ½ cup of the shredded mozzarella into the center of each piece of dough and arrange into a horizontal straight line. Distribute the meat evenly on top of each cheese pile. Top each with ¼ cup of pizza sauce.
6. Close roll by folding the long bottom part of the dough loosely over the mixture, then fold the tip over the folded dough and tuck under roll. The sides of the sausage roll will be exposed. Repeat with each of the pieces of dough.
7. Put the rolls on a baking sheet lined with foil and bake in the lower part of the oven until dough is golden brown, about 20 to 25 minutes.

Nutritional information per serving (½ sausage roll):

Calories 472 (35% from fat) • carb. 49g • pro. 29g • fat 18g
sat. fat 7g • chol. 70mg • sod. 1275mg • calc. 228mg • fiber 2g

CLASSIC WHITE BREAD

Fresh homemade bread is very simple to make with your Cuisinart® Food Processor.



- 2¼ TEASPOONS (1 PACKET)
ACTIVE DRY YEAST
- 2 TEASPOONS GRANULATED SUGAR
- ⅓ CUP WARM WATER
(105° TO 110°F)
- 4 CUPS UNBLEACHED,
ALL-PURPOSE FLOUR
- 3 TABLESPOONS UNSALTED BUTTER,
CUT INTO 1-INCH PIECES
- 1½ TEASPOONS KOSHER SALT
- 1 CUP COLD WATER
- NONSTICK COOKING SPRAY

Makes two, 1-pound loaves

1. In a 2-cup liquid measuring cup, dissolve yeast and sugar in warm water. Let stand until foamy, about 5 minutes.
2. Put the flour, butter and salt into the large work bowl fitted with the dough blade. Process on Low to sift, about 10 to 15 seconds.
3. Add cold water to yeast mixture. With the food processor running on Low, add the liquid through the small feed tube only as fast as flour absorbs it. Once dough cleans the sides of the work bowl and forms a ball, continue processing to knead for 45 seconds.
4. Transfer dough to a large bowl lightly dusted with flour. Cover with plastic wrap and allow to rise in a warm place until doubled, about 1 to 1½ hours.
5. After the dough has doubled in size, lightly coat two, 9-inch loaf pans with nonstick cooking spray. Reserve. Punch down dough and divide into two equal pieces. Form into 2 loaves and transfer to the prepared loaf pans. Cover with plastic wrap coated with the nonstick cooking spray. Allow to rise until dough is just above the tops of the pans, about 45 minutes to 1 hour.
6. Preheat oven to 400°F. Bake until tops are browned and loaf sounds hollow when tapped, about 30 to 35 minutes. Remove from pans and cool on wire rack. Cool completely before slicing.

Nutritional information per serving (based on 16 servings):

*Calories 137 (17% from fat) • carb. 25g • pro. 3g • fat 3g
sat. fat 1g • chol. 6mg • sod. 221mg • calc. 80mg • fiber 1g*

BUTTERY DINNER ROLLS

Fresh from the oven, warm rolls make any dinner extra special.



- 1/3** CUP WHOLE MILK
- 6** TABLESPOONS UNSALTED BUTTER,
PLUS MORE FOR PAN
- 3** TABLESPOONS GRANULATED SUGAR
- 1 3/4** TEASPOONS ACTIVE DRY YEAST
- 3** TABLESPOONS WARM WATER
(105° TO 110°F)
- 3** CUPS BREAD FLOUR
- 3/4** TEASPOON KOSHER SALT
- 1** LARGE EGG, LIGHTLY BEATEN
- EGG WASH (1 LARGE EGG
WHISKED WITH 1 TABLESPOON
WATER)

Makes 12 rolls

1. In a small saucepan, combine the milk, butter and sugar. Warm over low heat until the butter is melted. Remove from heat and reserve.
2. In a 2-cup measuring cup, dissolve the yeast in the warm water. Let stand until foamy, about 5 minutes.
3. Put the flour and salt into the large work bowl fitted with the dough blade. Process on Low to sift, 10 seconds. Add the milk mixture and egg to the yeast mixture. Gently stir to combine.
4. With the machine running on Low, slowly add the liquid through the feed tube and process until a dough ball forms. Continue processing to knead the dough, 45 seconds. Shape the dough into a smooth ball and transfer to a large mixing bowl; cover with plastic wrap. Allow to rise in a warm place until doubled in size, about 45 to 60 minutes.
5. Preheat oven to 450°F. Lightly butter a 9-inch round baking pan. Divide the dough into 12 equal pieces, about 2 ounces each. Roll into smooth rounds and arrange in the prepared pan. Cover with plastic wrap and allow to rise until the rolls have doubled in size, about 30 to 40 minutes.
6. Just before baking, gently brush the rolls with the egg wash. Bake until golden brown or an internal temperature of 200°F is reached, about 12 to 15 minutes.
7. Remove rolls from pan and cool on a rack for about 10 minutes before serving. For a softer roll, brush each with melted butter just after removing from the oven.

Nutritional information per roll:

Calories 144 (28% from fat) • carb. 7g • pro. 4g • fat 2g
sat. fat 1g • chol. 22mg • sod. 157mg • calc. 17mg • fiber 1g

PIZZA DOUGH

For more pizza recipes, go to Cuisinart.com.



2¼	TEASPOONS (1 PACKET) ACTIVE DRY YEAST
½	CUP WARM WATER (105°F TO 110°F)
1	TEASPOON GRANULATED SUGAR
4	CUPS UNBLEACHED, ALL-PURPOSE FLOUR, PLUS MORE FOR DUSTING
1½	TEASPOONS KOSHER SALT
1	TABLESPOON EXTRA VIRGIN OLIVE OIL
1	CUP COLD WATER

Makes three, 12-inch pizzas

1. Put the yeast, warm water and sugar into a 2-cup measuring cup. Let stand until foamy, about 5 minutes.
2. Put the flour, salt and olive oil into the large work bowl fitted with the dough blade. Pulse about 5 times to mix.
3. Add the cold water to the yeast mixture. With the food processor running on Low, slowly pour the liquid yeast mixture through the feed tube. Process until a dough ball forms. Continue processing to knead, about 1 minute. Dough will be slightly sticky.
4. Transfer dough to a large bowl that is lightly dusted with flour. Cover with plastic wrap and let rise in a warm place until doubled, about 45 minutes to 1 hour.
5. Punch down dough and divide into three portions. Use immediately, or store remaining portions in sealed, airtight plastic bags in the refrigerator for up to 2 days or in the freezer up to 3 months.
6. Bake using the pizza sauce recipe on page 23 or use to make focaccia. To make focaccia: Brush a baking sheet with 3 tablespoons of extra virgin olive oil. Stretch the dough onto the pan and cover to let rise again, an additional 45 minutes to 1 hour. Drizzle with an additional 1 to 2 tablespoons of extra virgin olive oil and sprinkle with kosher salt and fresh herbs if desired. Bake in an oven set to 425°F until golden brown and crispy, about 40 minutes.

TIP: Pizza dough can also be used to make pita bread: Roll 2-ounce pieces into disks, about ¼ inch thick and bake in a 450° F oven until puffed, about 3 minutes.

Nutritional information per serving (based on 8 servings):

*Calories 73 (7% from fat) • carb. 15g • pro. 2g • fat 1g
sat. fat 0g • chol. 0mg • sod. 134mg • calc. 0mg • fiber 0g*

FLAKY PASTRY DOUGH

This versatile dough can be used for sweet or savory treats.



- 2 CUPS UNBLEACHED,
ALL-PURPOSE FLOUR
- 1 TEASPOON KOSHER SALT
- 16 TABLESPOONS (2 STICKS)
UNSALTED BUTTER, COLD AND
CUT INTO ½-INCH CUBES
- ¼ CUP ICE WATER

Makes two, single-crust 9-inch tarts or one, double-crust pie

1. Put the flour and salt into the large work bowl fitted with the large chopping blade. Process on High to sift, 10 seconds.
2. Evenly disperse the butter on top of the flour mixture. Pulse until the mixture resembles coarse crumbs, about 14 pulses. Pour in water, 1 tablespoon at a time, and pulse until the mixture just forms a dough—you may not need all of the water.
3. Divide the dough equally into 2 pieces and form each into a flat disk. Wrap each with plastic wrap and refrigerate for at least 30 minutes or until ready to use, up to 1 week. This dough also freezes well, up to 3 months.

TIP: For a sweet pastry dough, add 1½ tablespoons of granulated sugar to the dry ingredients in the work bowl.

Nutritional information per serving (based on 16 servings):

*Calories 150 (66% from fat) • carb. 11g • pro. 2g • fat 11g
sat. fat 8g • chol. 30mg • sod. 133mg • calc. 0mg • fiber 0g*

TROPICAL FRUIT SALAD

Eat this fruit salad on its own or over waffles or ice cream. It's also a great base for adult beverages mixed with club soda and rum.



- 3 KIWIS, PEELED
- 2 BANANAS, HALVED
- 1 SMALL PAPAYA, PEELED AND SEEDED
- 1 PINEAPPLE, PEELED, QUARTERED AND CORED
- TOASTED COCONUT FLAKES, OPTIONAL

Makes 5 cups

1. Insert the dicing grid and blade. On Low, dice the kiwi. Then, on High, dice the banana, papaya and pineapple. Stir together and serve, sprinkled with the toasted coconut flakes, if desired.

Nutritional information per serving (½ cup):

*Calories 78 (4% from fat) • carb. 20g • pro. 1g • fat 0g
sat. fat 0g • chol. 0mg • sod. 3mg • calc. 19mg • fiber 2g*

APPLE TART

This classic French dessert is a sure way to impress guests.



- ½ RECIPE FLAKY PASTRY DOUGH (PAGE 59)
- 5 APPLES (ABOUT 2 POUNDS) OF YOUR CHOICE, PEELED, HALVED AND CORED, DIVIDED
- 2 TABLESPOONS UNSALTED BUTTER, PLUS 1 TABLESPOON MELTED
- ¼ CUP GRANULATED SUGAR
- 1 TABLESPOON FRESH LEMON JUICE
- 1 TEASPOON PURE VANILLA EXTRACT
- UNBLEACHED, ALL-PURPOSE FLOUR, FOR ROLLING
- ¼ CUP APRICOT JAM, WARMED

Makes one, 9-inch tart

1. Insert dicing grid and blade. Dice 3 apples. Put apples into a medium saucepan with the butter, sugar and lemon juice. Gently simmer over low heat until very tender and liquid, about 30 to 40 minutes. When apples are done cooking, remove from heat, stir in vanilla extract and cool.
2. While apples are cooking, blind bake the pastry dough: Preheat oven to 350° F. On a lightly dusted surface, roll out the pastry dough into a circle about ⅛ inch thick. Transfer to a 9-inch tart pan (with removable bottom) and gently press dough into the sides and bottom of pan. Use the rolling pin to roll over the tart pan and trim the edges of the dough. Gently prick the bottom of the pan with a fork, being sure not to go all the way through. Coat a piece of aluminum foil with nonstick cooking spray. Place, sprayed side down, onto the top of the dough in the tart pan. Fill with pie weights (dried beans or rice can be used). Bake until bottom of crust is no longer wet, about 20 minutes. Gently remove foil with pie weights and continue baking until golden brown, an additional 10 to 12 minutes. Remove pan from oven and cool slightly.
3. While apple mixture and tart shell are cooling, adjust the slicing disc to setting 3. Insert the slicing disc and slice remaining 2 apples. Toss with 1 teaspoon cinnamon. Reserve in bowl.
4. Pour cooked and cooled apple mixture into the tart pan and spread evenly. Arrange apple slices over the apple mixture in concentric circles. Brush with 1 tablespoon melted butter. Bake until apple slices are soft and lightly golden, about 25 to 30 minutes.
5. Remove from oven and brush with the warm apricot jam. Let cool slightly in pan and then carefully remove from pan. Serve warm.

Nutritional information per serving (based on 8 servings):

Calories 287 (47% from fat) • carb. 37g • pro. 2g • fat 15g
sat. fat 11g • chol. 41mg • sod. 138mg • calc. 11mg • fiber 3g

DOUBLE CHOCOLATE ZUCCHINI BREAD

The zucchini keeps this quick bread very moist, without much added fat.



	NONSTICK COOKING SPRAY
1¾	CUPS UNBLEACHED, ALL-PURPOSE FLOUR
½	CUP COCOA POWDER
2	TEASPOONS INSTANT ESPRESSO POWDER
1	TEASPOON GROUND CINNAMON
1	TEASPOON KOSHER SALT
1	TEASPOON BAKING POWDER
¼	TEASPOON BAKING SODA
	PINCH NUTMEG
1	LARGE ZUCCHINI (ABOUT 12 OUNCES), TRIMMED AND CUT TO FIT FEED TUBE
1	CUP PACKED LIGHT BROWN SUGAR
2	LARGE EGGS
½	CUP VEGETABLE OIL
½	CUP CHOCOLATE CHIPS (SEMISWEET OR MILK CHOCOLATE)

Makes one, 9-inch loaf

1. Preheat oven to 325° F. Lightly coat a 9-inch loaf pan with cooking spray. Reserve.
2. Combine the flour, cocoa powder, espresso powder, cinnamon, salt, baking powder, baking soda and nutmeg in a medium bowl. Reserve.
3. Insert the shredding disc with the medium side facing up. Shred zucchini. Add to the bowl with the reserved dry ingredients.
4. Put the sugar, eggs and oil into the large work bowl fitted with the large chopping blade. Process on High for 30 seconds. Add dry ingredients and pulse, to just combine, about 8 to 10 times. Remove blade. Fold in chocolate chips. Pour batter into prepared loaf pan.
5. Bake until a cake tester inserted into the center comes out clean, about 1 hour.
6. Let cool in pan and serve warm if desired.

Nutritional information per serving (based on 12 servings):

*Calories 272(42% from fat) • carb. 38g • pro. 4g • fat 14g
sat. fat 4g • chol. 36mg • sod. 240mg • calc. 8mg • fiber 2g*

PECAN SHORTBREAD LINZER COOKIES

These cookies can be cut into any shape, making them perfect for any holiday.



½	CUP TOASTED PECAN HALVES
¼	CUP GRANULATED SUGAR
3	CUPS UNBLEACHED, ALL-PURPOSE FLOUR, PLUS MORE FOR ROLLING
1	CUP CONFECTIONERS' SUGAR, PLUS EXTRA FOR DUSTING
½	TEASPOON KOSHER SALT
20	TABLESPOONS (2½ STICKS) UNSALTED BUTTER, ROOM TEMPERATURE, CUT INTO 1-INCH PIECES
1	TEASPOON PURE VANILLA EXTRACT
¾	CUP RASPBERRY JAM, WARM

Makes 45 cookie sandwiches

1. Put the pecans and sugar into the large work bowl fitted with the large chopping blade. Pulse until the mixture resembles a coarse meal, remove and reserve. Put the flour, confectioners' sugar and salt into the work bowl. Pulse to mix dry ingredients together, about 2 to 3 times. Add the pecan/sugar mixture to dry ingredients.
2. Distribute the butter evenly over dry ingredients in work bowl. Pulse to cut in the butter, 10 to 12 pulses. Add the vanilla extract. Continue to pulse until the mixture forms a dense dough. Remove dough and divide into two equal disks, wrap in plastic wrap and place in refrigerator for at least one hour.
3. Preheat oven to 350°F. Line two baking sheets with parchment paper. Set aside.
4. Remove 1 dough disk from refrigerator. On a floured surface, roll the dough into an even ½-inch thickness. Using a 2-inch fluted round cookie cutter, cut rounds and place on parchment-lined baking sheet. Bake for 16 to 20 minutes, turning baking sheet halfway through bake time, until the edges are golden. Remove from oven and transfer cookies to a cooling rack.
5. Repeat rolling and baking with remaining dough, this time using a ¾-inch round cutter to cut out centers of the 2-inch fluted rounds.
6. Once cookies are cooled, spread ½ tablespoon of the warm jam over the entire surface of the uncut rounds. Top with the cutout rounds and press gently together to adhere. Dust the tops of the cookies with confectioners' sugar.

Nutritional information per cookie sandwich:

Calories 66 (11% from fat) • carb. 14g • pro. 1g • fat 1g
sat. fat 0g • chol. 0mg • sod. 25mg • calc. 2mg • fiber 0g

STRAWBERRY FROZEN YOGURT

Substitute your favorite frozen fruit if desired; plus, top with fresh fruit diced in your Cuisinart® food processor.



2 CUPS FROZEN STRAWBERRIES
½ CUP YOGURT, PLAIN OR LOWFAT
1 TABLESPOON AGAVE NECTAR

Makes 2 cups

1. Put the strawberries into the large work bowl fitted with the large chopping blade. Pulse to break up, about 15 to 20 times. Add yogurt and agave, and process on High until smooth, about 1 minute.

Nutritional information per serving (½ cup):

*Calories 54 (7% from fat) • carb. 13g • pro. 2g • fat 1g
sat. fat 0g • chol. 0mg • sod. 23mg • calc. 48mg • fiber 1g*

