

AeroGarden®

Quick Planting Guide

Simple Steps to Get Your AeroGarden Farm Up and Growing



Farm Plus & Farm

Welcome to the world of indoor gardening!

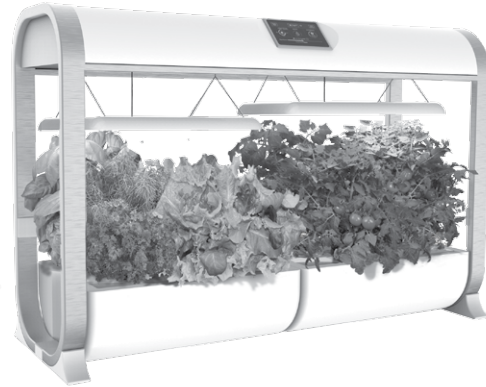

Keep this Guide!

AeroGarden Farm Model number: 100024 - BLK / WHT

AeroGarden Farm Plus Model number: 100025 - BLK / WHT

Electrical Rating: 120V~60Hz, 1.1A

Electrical Rating: 120V~60Hz, 1.1A

IMPORTANT SAFETY INSTRUCTIONS

When using this AeroGarden electrical furnishing, basic precautions should always be followed, including the following: Read all instructions before using this AeroGarden furnishing. SAVE THESE INSTRUCTIONS

1. To reduce the risk of electric shock, the AeroGarden Farm has a specific plug. Do not change the plug in any way.

DANGER – to reduce risk of electric shock:

2. Always unplug the AeroGarden Farm from electrical outlet before cleaning.

WARNING – to reduce risk of burns, fire, electric shock, or injury to persons:

3. Unplug AeroGarden Farm from outlet before putting on or taking off parts.
4. Use AeroGarden Farm only for its intended use as described in the instructions. Do not use attachments not recommended by manufacturer.
5. Never operate AeroGarden if it has a damaged cord or plug, if it is not working properly, if it has been dropped and damaged, or if it has been dropped in water. If any of these conditions occur/exist, contact customer service.
6. Keep cord away from heated surfaces.
7. Never operate furnishing with air openings blocked. Keep air openings free of lint, hair, and the like.
8. Never drop or insert any object into any electrical openings.
9. Do not use outdoors.
10. Do not operate where aerosol (spray) products are being used or where oxygen is being administered.
11. Do not touch moving parts or hot parts such as pumps, lights, reflective surfaces, and the like.
12. To disconnect, remove plug from outlet.
13. Do not place or submerge base, cord, plug, or Light Hood in water or other liquid to clean it.
14. Do not allow water to contact hot LED Grow Lights.
15. Use only approved and supplied parts and accessories. Use only AeroGarden LED Grow Lights with this AeroGarden model. Use of any other kind of accessory is not recommended.
16. Do not use AeroGarden for other than intended purpose.
17. This product is intended for household and residential use only. This product is not approved for commercial applications.
18. If supply cord is damaged, it must be replaced by manufacturer, its service agent, or similarly qualified technician in order to avoid a hazard.
19. Electrical wiring must be in accordance with local regulations.
20. This appliance is not intended for use by persons (including children) with reduced physical, sensory or mental capabilities, or lack of experience and knowledge, unless they have been given supervision or instruction concerning use of appliance by a person responsible for their safety.
21. Children should be supervised to ensure they do not play with the appliance.

Warning: Changes or modifications to this unit not expressly approved by the party responsible for compliance could void the user's authority to operate the equipment.

Note: This equipment has been tested and found to comply with the limits for a Class B digital device, pursuant to Part 15 of the FCC Rules. These limits are designed to provide reasonable protection against harmful interference in a residential installation. This equipment generates, uses and can radiate radio frequency energy and, if not installed and used in accordance with the instructions, may cause harmful interference to radio communications. However, there is no guarantee that interference will not occur in a particular installation. If this equipment does cause harmful interference to radio or television reception, which can be determined by turning the equipment off and on, the user is encouraged to try to correct the interference by one or more of the following measures:

- Reorient or relocate the receiving antenna.
- Connect the equipment into an outlet on a circuit different from that to which the receiver is connected.
- Increase the separation between the equipment and receiver.
- Consult the dealer or an experienced radio/TV technician for help.

This device complies with Part 15 of the FCC Rules. Operation is subject to the following two conditions: (1) this device may not cause harmful interference, and (2) this device must accept any interference received, including interference that may cause undesired operation. The device has been evaluated to meet general RF exposure requirement.

Welcome!

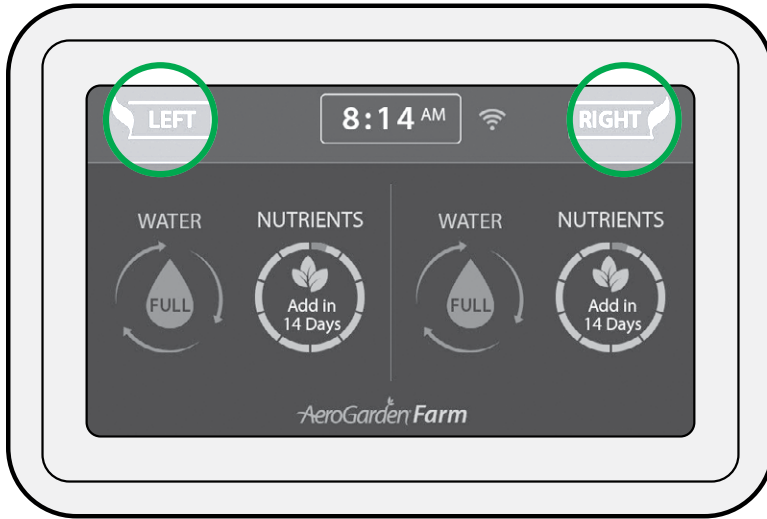

Your AeroGarden Farm operates as two independent 12-pod gardens. Plant one garden, Left or Right side, and then select the opposite to plant the other side. Each side is controlled independently.

Once you have selected your Left or Right side garden from the Home Screen, touch the Quick Plant option on the control panel for step-by-step planting instructions.

 **Download the Free AeroGarden App by searching for 'AeroGarden' in your mobile App store.**

Plant Your Garden in 3 Easy Steps

Quick Plant

Planting Your Garden in 3 Steps

Quick Plant is the fastest and easiest path to starting a new garden. The pre-set Quick Plant option provides optimal growth based on the plant type you select. Follow the easy instructions on-screen. More detail is provided on the following pages.

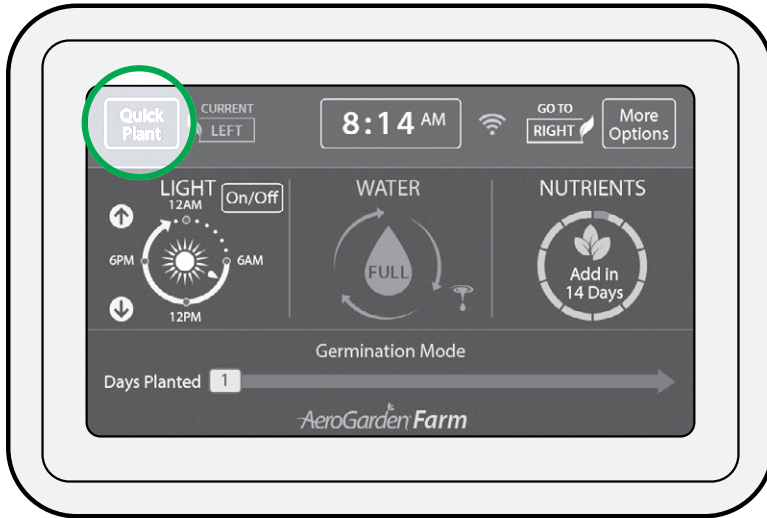

STEP 1 Add Water

- Add water to “Max Fill” indicator located under the Water Port.
- Use room temperature tap water or **bottled distilled water**. DO NOT USE WELL WATER which may interfere with your nutrients, or softened water, as it contains levels of sodium usually harmful to plants.
- The 'Low Water' reminder alert will appear on the control panel when the water level is too low. For best results, keep the water level topped up to the “Max Fill” at all times.

STEP 2 Add Nutrients—Liquid Plant Food

- Nutrient instructions are printed on the packaging, as well as in the Seed Pod Kit Instructions booklet. Read and follow the instructions carefully!
- Use only the recommended amount of Liquid Plant Food.
- Add nutrients directly into Bowl when first planting your Seed Pod Kit, and when the ‘Add Nutrients’ reminder activates (every 2 weeks).
- Do not overfeed! More isn’t better. Too much nutrient can harm your plants.

Nutrient Feeding Tip: Always top off water level when adding Liquid Nutrients. For best results, top off the water level in your garden regularly.

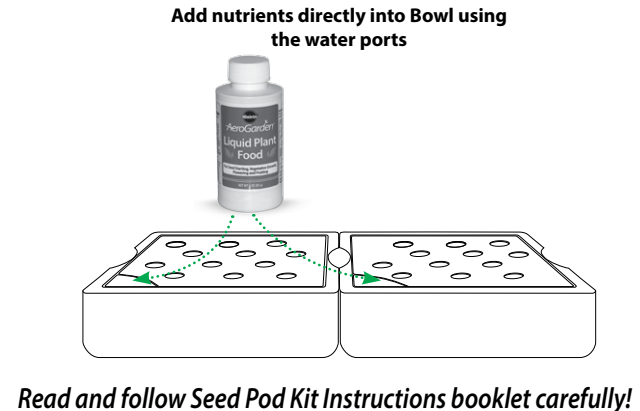
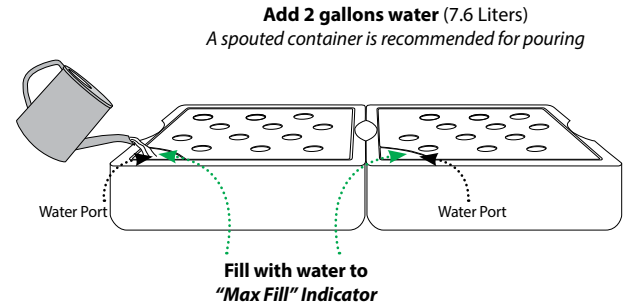

STEP 3 Add Seed Pods & Grow Domes

- Insert Seed Pods into openings in Grow Deck.
- Seed Pod Labels often identify plant height to assist with placement. Look for height noted on Labels.
- Plants grow best and look best if medium or tall plants are in back openings, and short plants are in front openings (see diagram).
- Seed Pod Kits for Tomatoes and Peppers often include both Seed Pods and Plant Spacers. Plant Spacers allow your Tomato/Pepper plants ample room to grow. The correct amount of seeded pods are provided to maximize harvests.
- **Do not** remove Labels from Seed Pods. The labels identify the plant type and plant height, show the germination time, and inhibit algae growth.
- Place a Grow Dome over each Seed Pod.
- Grow Domes rest on Seed Pods and may not 'snap' into place. Also, it is not necessary for Grow Domes to cover Plant Spacers in your AeroGarden.
- Leave Grow Domes on the Seed Pods until plants have sprouted and their leaves nearly touch the domes.
- Once removed, Grow Domes may be reused/recycled.

Congratulations!

You're on your way to a beautiful garden.

Insert a Seed Pod or Plant Spacer into every opening in Grow Deck

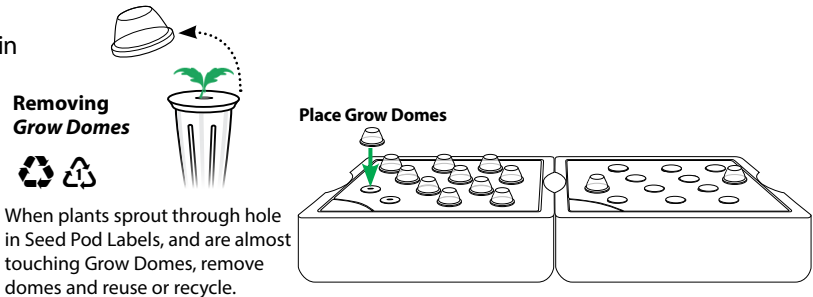
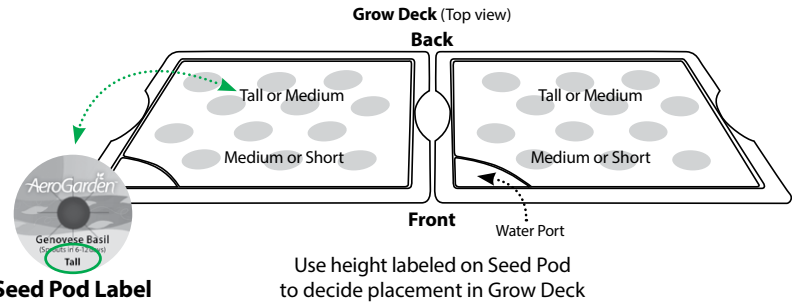
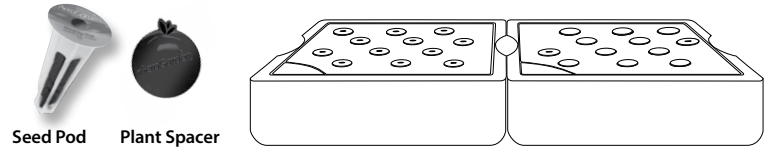

Control Panel

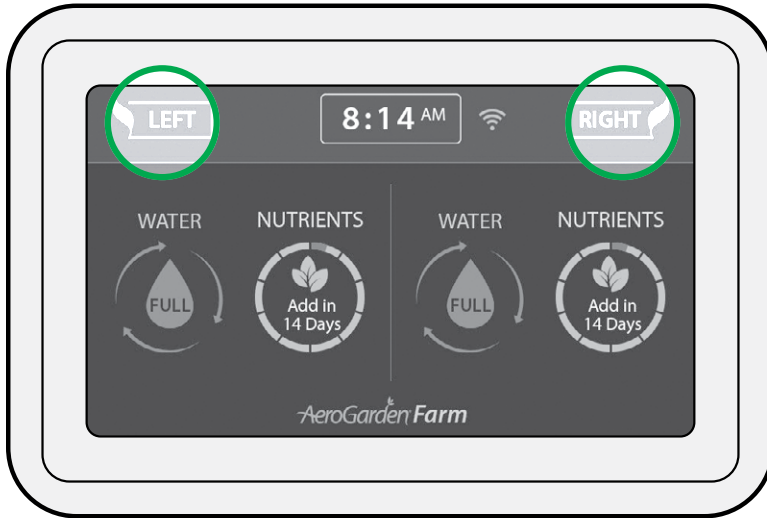







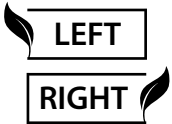

Touch Screen

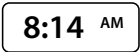
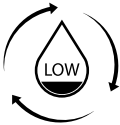
The AeroGarden Farm's touch screen control panel makes it easy for anyone to grow indoors. Beginners get step-by-step instructions on the planting process and tips to improve gardening skills. It also allows advanced users to customize every aspect of their garden, expanding the possibilities of what can be grown indoors.

From the Home Screen (pictured here) press the Left or Right side to enter the controls for the Left or Right garden. The panel view will change to display current settings for that garden.

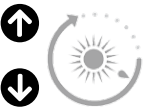
Control Panel Settings

 <p>LEFT</p> <p>RIGHT</p>	<p>LEFT/RIGHT: The Left & Right arrows allow you to access the Home screen of each side of your AeroGarden Farm.</p>		<p>WI-FI: The Wi-Fi icon allows you to access the Wi-Fi setting of your AeroGarden Farm, as well as connect your AeroGarden Farm to your AeroGarden App.</p>
	<p>CLOCK: Set your AeroGarden Farm's clock to your local time.</p>		<p>WATER: The Water icon reminds you when it is time to add water, and when pressed also displays the current pump setting and test pump feature.</p>
	<p>LIGHT: The Light icon shows the current time, as well as when your light is scheduled to turn On and Off each day.</p>		<p>NUTRIENTS: The Nutrients icon shows how many days are left until it is time to add nutrients.</p>
	<p>LIGHT ON/OFF: Temporarily turns lights On or Off. Your lights will automatically go back to their programmed settings at the start of the next On/Off cycle.</p>		<p>QUICK PLANT: Press the Quick Plant button to start a new garden, and follow the simple step by step instructions to set up all garden functions.</p>
	<p>LIGHT UP/DOWN: The up and down arrows next to your light icon allows you to raise and lower your grow lights. Keep your lights 4-6 inches above your plants for better results.</p>		<p>MORE OPTIONS: The More Options button gives you access to a wide variety of garden functions, as detailed next.</p>

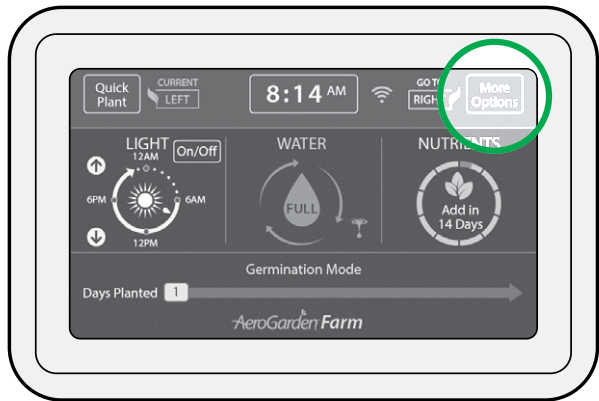

MORE OPTIONS

- ▶ **Clock** – Use this to set your clock to the current time (initially set during Quick Plant).
- ▶ **Light** – Use this if you want to change the times your LED Grow Light will go on and off, or to customize the number of hours your grow lights turn on per day.
- ▶ **Nutrients** – Allows you to customize or reset your nutrient reminders. The nutrient alert is preset to activate every 14 days to remind you to add nutrients, but can be changed if your plants have other nutrient requirements. This is not necessary in normal use.
- ▶ **Pump** – Allows you to customize or reset your Pump settings and also test the pump.
- ▶ **Quick Plant** – With just a few touches, Quick Plant helps you select the settings you need for the type of plants you are growing. Use this for the fastest and easiest path to planting a new garden.
- ▶ **Wi-Fi** – Connect your AeroGarden Farm to your preferred network and control your garden remotely on any device using the AeroGarden App.
- ▶ **Contact Us** – Provides phone and email contact information for customer service.
- ▶ **Help & Tips** – Use this for easy access to helpful gardening tips and customer support information.
- ▶ **Reset Defaults** – Returns key garden functions to original factory default settings.
- ▶ **Order Supplies** – Easy access to replacement part numbers and customer support contact information.
- ▶ **Garden Status** – All your current settings (Lights, Pump, etc.) can be viewed in Garden Status.
- ▶ **Set Audio Alerts** – Audio Alerts can audibly remind you when it is time to add water and nutrients. You can also turn Audio Alerts On or Off, and set start/stop times here.
- ▶ **Drain Garden** – In a few easy steps, drain your garden to perform a rinse and refill. Your plants will thank you.

Using The Farm Trellis System

This Trellis System will support your large plants, such as tomatoes and peppers, by guiding the plants upward as they grow. Once your plants reach a height where they would benefit from extra support, attach the **Trellis System** to the **Metal Frame** of your AeroGarden Farm as pictured. The Trellis can be repositioned as plants grow.

How to Assemble Trellis System

- 1 Attach magnetic ends of long trellis cord to the opposite inner side of each of the posts on the metal frames of your AeroGarden Farm.
- 2 Pinching the clips at the end of the small trellis cords, attach them to the long trellis cords at any desired interval.
- 3 LED Lights will move between Long Trellis cords. Short Trellis cords can be positioned to allow plant support on half of the garden and easy light movement on the other half.

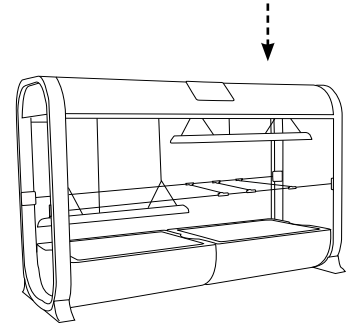
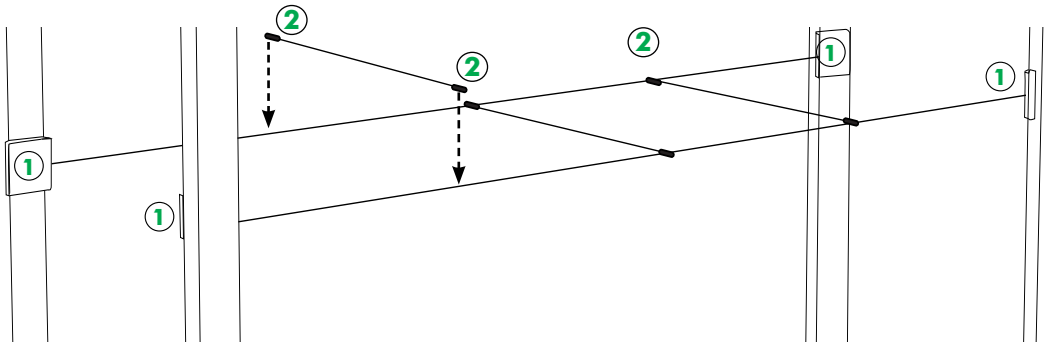

Gardening Tips For Maximum Harvests

PLANTING

- ▶ Many Seed Pod labels identify plant height. Gardens grow and look their best when tall plants are planted in the back, medium plants along the sides, and short plants in front. If plants are all the same size, like Salad Greens, they can be planted anywhere.
- ▶ Do not remove Labels from Seed Pods. The labels identify the plant type and plant height, show the germination time, and inhibit algae growth.
- ▶ Grow Domes help regulate moisture and temperature for optimal germination. Leave them on until plants are nearly touching the domes.
- ▶ Seed Pod Kits for large plants like Tomatoes and Peppers often receive fewer than 12 pods to compensate for the large plant size. Place Seed Pods in each back/side opening and in the center front opening. Put Plant Spacers in the remaining openings.

GERMINATION

- ▶ Some seeds germinate in less than 24 hours. Some take 24 days or more. Most labels give an estimate of how long your seeds will take to germinate but many factors impact germination.
- ▶ As a rule, if you are comfortable, so are your plants. Plants are impacted by temperature. Cold weather plants, like Salad Greens, germinate better in cooler weather. Heat lovers, like Tomatoes and Peppers, will germinate faster in warmer temperatures (above 70 degrees F). But don't sweat it! While they may take a bit more time, your seeds will germinate.
- ▶ If you are growing your own seeds, plant 5-6 seeds per pod and check the seed packet for information regarding temperature and days to germination.

PRUNING

- ▶ Not pruning is the number one mistake made by new AeroGardeners! *Prune early and often and enjoy the small harvests!*
- ▶ Pruning the plant just above a new leaf set (Diagram A) will ensure that slow-growing and low-growing plants in your garden get all the light they need to flourish.
- ▶ Prune often to maintain a healthy garden, but never take more than 1/3 of each individual plant at a time.
- ▶ Plants compete for light. Left untended, more aggressive growers can actually block enough light to suppress growth of their slower growing neighbors, and eventually they can die off due to lack of light. Spreading leaves must be trimmed (Diagram B) to make sure that slow growers get enough light to thrive and produce big yields.
- ▶ Finally, pruning = harvesting. Each time you prune you get to enjoy fresh herbs in a salad, sandwich or even pizza. Also, a full, bushy garden looks much better than one giant, spindly plant surrounded by straggly, light starved neighbors. Pruning also releases a wonderful scent. So prune!

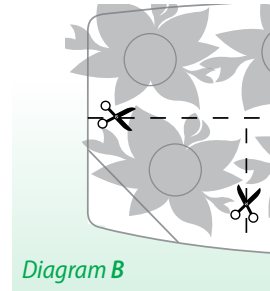
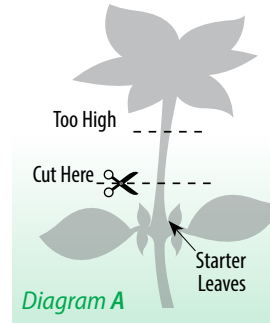

WATER

- ▶ While the AeroGarden Farm's control panel will remind you when water gets low, best results are achieved by topping off water regularly.
- ▶ Plants grown in the AeroGarden Farm are designed to thrive with most municipal tap water.
- ▶ Use of well water is not recommend, as most well water contains a high amount of dissolved solids that upset the balance of your nutrients. This can result in plants suddenly browning, or just not growing well.
- ▶ Do not use softened water as it contains too much sodium and will usually harm your plants.
- ▶ Do not fill Bowl past "Max Fill" indicator.
- ▶ Test your pump by clicking on the water icon of your Farms left or right home page. Then click on "Pump Settings" and then "Test Pump".

LIGHTS

- ▶ Plants love light! Keep your Grow Lights 4-6 inches above your plants for better results.
- ▶ You do not need to replace your LED lights unless individual diodes start to fail. Diodes have a 3-5 year life span.

NUTRIENTS—LIQUID PLANT FOOD

- ▶ Typically, your plants will need nutrients every 2 weeks.
- ▶ Follow instructions for feeding amounts printed on the nutrient packaging.
- ▶ Add nutrients directly into the Bowl through the Water Port.
- ▶ Nutrient requirements may change as plants grow. See nutrient packaging for details.
- ▶ More isn't better. Resist the temptation to add "just a little extra." Too much nutrient can hurt your plants.
- ▶ For best results, try a "Rinse and Refill" once a month when it's time to add nutrients. Use the 'Drain your Garden' option from your 'More Options' or 'Water' menus.

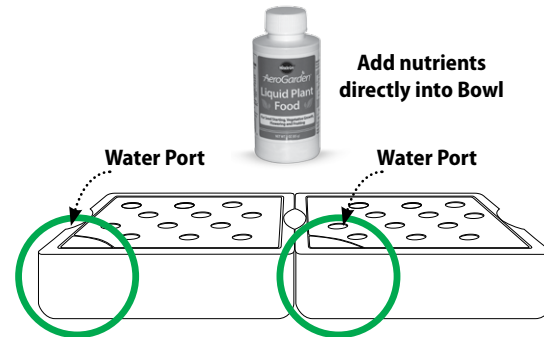

POLLINATING

Because most people don't have bees in their home, you will need to start pollinating your fruiting plants (tomatoes, peppers, strawberries, etc) once they begin to flower (approximately 4 – 6 weeks after planting). To pollinate, use one or more of the following methods:

- ▶ Place an open hand inside plant branches and gently move your hand back and forth to shake the plant and spread the pollen.
- ▶ Place a fan near your plants and the moving air will pollinate your plants.
- ▶ Use our “Be the Bee Pollinator” to spread the pollen. “Be the Bee Pollinators” are available at AeroGarden.com
- ▶ Strawberries can benefit from more aggressive pollination. Using the “Be the Bee”, touch each flower with the brush, moving from flower to flower.

HARVESTING

- ▶ Many first-time growers are hesitant to harvest. Don't be! Most gardens will produce more, for a longer period, with frequent harvests. You almost can't begin to harvest (prune) early enough.
- ▶ AeroGardens work best with a harvesting method called “cut and come again.” Simply put, you enjoy frequent small harvests and then watch as the plants rapidly regrow - ready for harvest again and again.

- ▶ Enjoy frequent, smaller harvests for the first month or two until plants mature and larger harvests are available.
- ▶ Harvest often to maintain a healthy garden, but never take more than 1/3 of each individual plant at a time.
- ▶ For Salad Greens, cut the top 2 inches off the entire garden, or harvest large leaves individually by cutting off at the base of the plant.

DRAIN YOUR GARDEN

- ▶ Before you start, make sure to have a separate container to hold the emptied water.
- ▶ Select the side you want to empty by selecting Left or Right

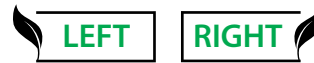

- ▶ To access the ‘Drain Your Garden’ procedure, press the  icon from your Home or Water setting page. You can also access it from the ‘More Options’ button, select ‘More +’, then click on ‘Drain Garden’.
- ▶ Follow the instructions on your Touch Screen.



U.S. CAUTION – You are cautioned that any changes or modifications not expressly approved in this manual could void your authority to operate this equipment.

User Maintenance: Any servicing is to be performed by an authorized service representative. Use original packaging for storage when the appliance is not used.

Disconnect power before servicing or replacing lights. Use only AeroGarden LED Light Hood replacement.

DO NOT SUBMERGE

HOUSEHOLD USE ONLY

Do not immerse cord in water or other liquid, and unplug cord from outlet when not in use.

To reduce the risk of electric shock, this furnishing has a polarized plug (one blade is wider than the other). This plug will fit in a polarized outlet only one way. If the plug does not fit fully in the outlet, reverse the plug. If it still does not fit, contact a qualified electrician to install the proper outlet. Do not change the plug in any way.

CAUTION!

TO PREVENT ELECTRIC SHOCK, MATCH WIDE BLADE OF PLUG TO WIDE SLOT, FULLY INSERT.

POUR ÉVITER UN CHOC ÉLECTRIQUE, PRÉSENTER LA LAME LARGE À LA FENTE LARGE ET POUSSER JUSQU'AU FOND.

LIMITED WARRANTY

WHAT IS COVERED – This warranty covers any defects in materials or workmanship, with the exceptions stated below.

HOW LONG COVERAGE LASTS – This warranty runs for one (1) year on this AeroGarden and LED Grow Lights, from the date of original purchase, for the original purchaser/user.

WHAT IS NOT COVERED – The warranty shall not apply to problems arising from: normal wear; failure to adhere to enclosed operating instructions; serial numbered products if the serial number has been removed or defaced; products subject to negligence, accident, improper use, maintenance or storage; products damaged by circumstances beyond AeroGrow International Inc.'s control; loss or damage to removable parts; or products modified (including, but not limited to, modifications through the use of unauthorized parts or attachments) or repaired by anyone other than AeroGrow International, Inc., or its designee. This warranty excludes all incidental or consequential damages.

WHAT AEROGROW WILL DO – AeroGrow International, Inc., at its option, will repair any defects in materials or workmanship or will replace these products with ones of similar features and price. AeroGrow International, Inc.'s sole obligation and your exclusive remedy under this warranty shall be limited to such repair or replacement.

TO RETURN THIS PRODUCT – If you have questions or concerns regarding your AeroGarden, please contact Customer Service at 1-800-476-9669. Please do not return any product without contacting AeroGrow for return authorization. Unauthorized returns, as well as C.O.D. shipments, will be refused. For more information regarding returns, please see the Returns section at www.AeroGarden.com

Due to continuing improvements, actual product may differ slightly from the product described herein. Some states do not allow the exclusion or limitation of incidental or consequential damages, so the above limitation or exclusion may not apply to you. This warranty gives you specific legal rights, and you may have other legal rights that vary from state to state.



If you have any questions please feel free to contact our customer service representatives at 1-800-476-9669 (USA) or 1-800-611-9058 (Canada)

NEED SUPPLIES, ACCESSORIES OR INFORMATION? Visit Our Website: www.AeroGarden.com



We also have an active Facebook Community that loves to answer questions at facebook.com/aerogarden. "Like" us for special offers and community fun!

AeroGrow International, Inc., P.O. Box 18450, Boulder, CO 80308-1450
©2018 AeroGrow International, Inc. 022318 AA