

L'ART DU JARDIN

## ALSACE

WOOD-FIRED OVEN/GRILL COMBINATION



DISTRIBUTED BY :

LONGVIEW PRODUCTS LLC

#229 3760 SIXES ROAD, SUITE 126

CANTON, GA 30114

770-517-3527 [WWW.LONGVIEWPRODUCTS.COM](http://WWW.LONGVIEWPRODUCTS.COM)

# V3 Alsace



## Introduction

We thank you very much for having purchased our V3 Alsace Multi function Oven and Barbecue.

This booklet contains instructions regarding the functioning and correct use of the oven and its maintenance.

The manufacturer reserves the right to make changes or improvements to its products at any time without prior notice.

Distributed by : Longview Products, Canton GA





## Warning

- All L'Art du Jardin wood fired ovens are for use outdoors only - do not use them in any enclosed area
- Always follow all instructions and safety manuals.
- Use only hardwood or chunk charcoal - do not use soft woods(pine), painted or stained wood, pressure treated wood or wood treated with other preservatives.
- Always wear protective clothing, including heat resistant gloves and apron.
- Do not move the oven after the fire has started and before the oven is cool.
- Use only on flat and level surfaces.
- Assembly requires two adults capable of safely lifting 110 pounds each (50 Kg).
- Although every effort is made to machine all edges it is possible for some edges to be sharp - do not run any part of your body along any edges.
- Always wait until the fire is out and the oven cool before cleaning or covering.
- Never use an abrasive cleaner on any of the oven's surfaces.
- WHEN GRILLING MAKE SURE THE FLAME LEVEL IS NOT DANGEROUSLY HIGH BEFORE TILTING THE OVEN UP.

Note : By products from the combustion of charcoal, wood and other fuels are known by the state of California to cause cancer, birth defects, and other reproductive harm.



## Before using

- Remove all packing materials and discard.
- Remove the cooking stones and carefully set aside, do not drop as they can break. Do not use detergent on the cooking stones.
- Clean the inside and outside of the oven using warm water and a mild detergent to remove the special coatings applied during the manufacturing process, as well as any residue or moisture build up that may occur during transportation. These materials can emit unpleasant smells when the oven is lit for the first time.
- After the oven is dry replace the stones. Then light a fire in the box allowing it to burn as written page 4 in «Starting the fire for the first time». Allow the fire to burn at approximately 350°F/175°C for a minimum of 2 hours.





## Starting the fire for the first time

- Obtain some small size dry wood, no longer than 12 inches/30 cm.
- Make sure the fire box is inserted all of the way into the oven.
- Insure that the Ash Tray is inserted under the fire box as showed page 5.
- Pull out the round safety pin on the left side of the oven, using the lifting handle raise the oven up to expose the grilling area (for safety insure the safety pin spring snaps it into the highest position, there are 3 positions - baking, grilling, and a middle position for using a rotisserie), then insert the stainless steel grill.
- Pull out the safety pin and use the lifting handle to return the oven to the baking position, open the oven door and carefully insert the cooking stones in the oven.
- For seasoning use hardwood, no longer than 12 inches, 30 cm, or chunk charcoal.
- Light the fire in the firebox.
- Insure that the air vents on the firebox door are in the open position.
- Stoke the fire every 10 minutes.
- Maintain a temperature of 350F/175°C for at least 2 hours, opening the oven door every few minutes to allow odors to escape.
- Allow oven to cool before storing or moving.

Oven Position



Grill Position



Safety Pin closeup

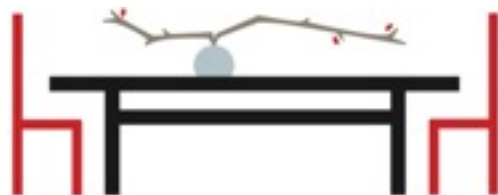

L'ART DU JARDIN

## Oven Components

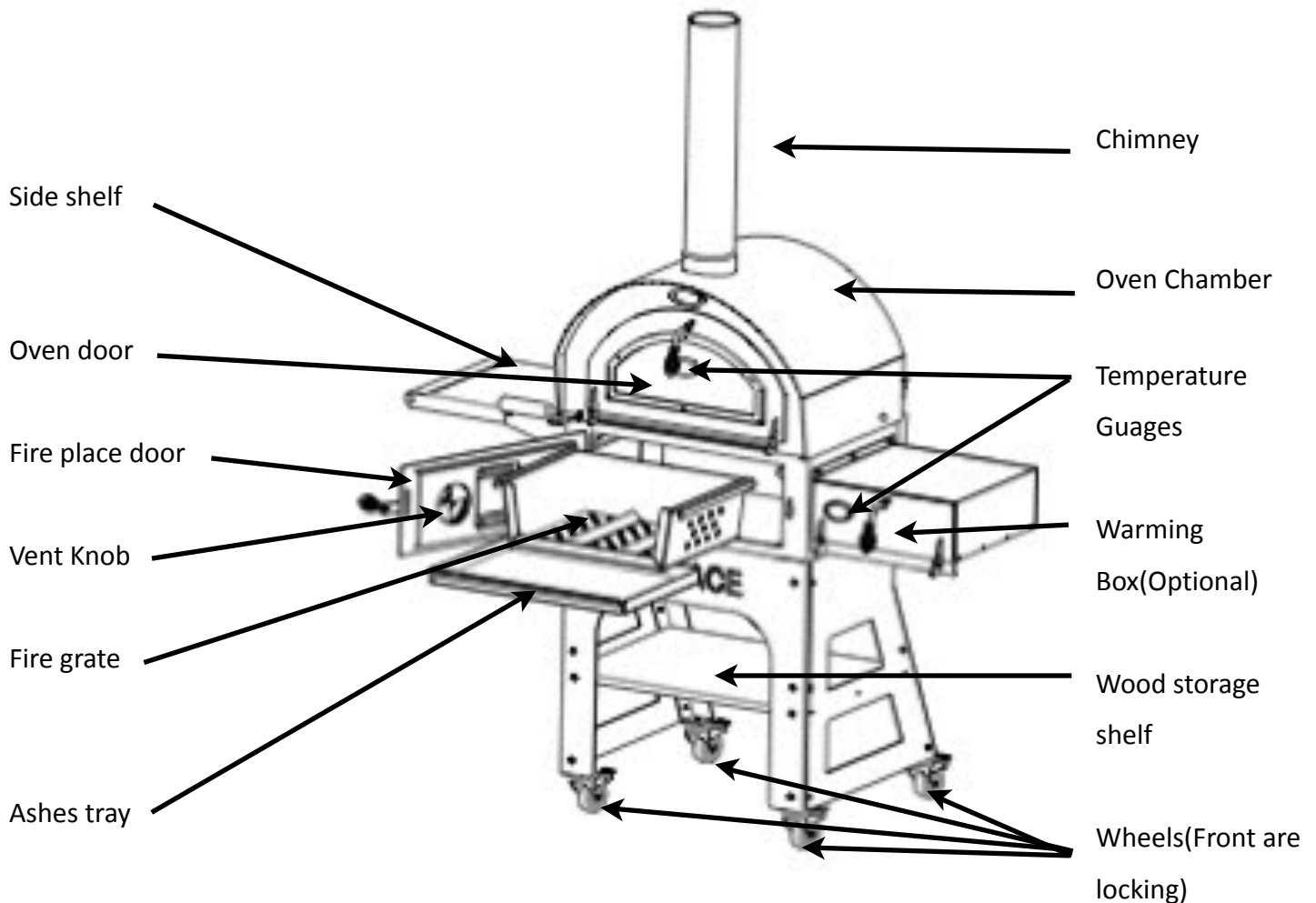

### Before Using the Alsace Woodfired Oven/BBQ :

- Carefully read all instructions and guides paying attention to all warnings.
- The Alsace oven is designed for consumer use only, commercial use voids all warranties.
- Before using, remove all packing materials, stickers and protective wraps and discard.
- Follow carefully the section titled «Starting the fire for the first time» prior to using the oven.
- **DURING USE ALL OVEN SURFACES GET VERY HOT - DO NOT TOUCH, KEEP CHILDREN AND PETS AWAY FROM THE OVEN. ALWAYS USE HEAT RESISTANT GLOVES WHEN USING THE OVEN. ALLOW THE OVEN FIRE TO GO OUT THE OVEN TO COOL DOWN BEFORE CLEANING OR REMOVING ASHES.**
- Keep all operating manuals handy and refer to them prior to each use.

## Operating the Oven and Grill

The Alsace multi-function outdoor wood-fired Oven/Grill is easy to use and produces excellent results! By design, it uses less wood than comparable models making it very economical as well.

You can use the Alsace as an oven for baking artisan pizzas and breads, tarte flambes, vegetables, meats, fish and desserts - just like using your home kitchen oven. Then 'presto change-o' in less than 5 seconds using our patented tilt function, you can transform your outdoor oven into a great barbecue for grilling meats, fish and vegetables.

The versatile Alsace will quickly become an outdoor social hub for family, friends and fun as you prepare a wide variety of delicious meals laced with the delicate smoke of a smoldering wood fire. In every season, it's easy to bake or grill just about anything in the multi-function Oven/Grill. Meals will be more memorable cooked outdoors in the Alsace, with the aromatic scents of crispy artisan pizzas, succulent roasts, juicy grilled ribs or slow-cooked stews for your family and friends.

The Alsace is manufactured using double wall construction, two pieces of 1/8th inch steel separated by an air space. The heat travels up to quickly heat the thick stones on the oven floor and at the same time moves through the air space on the sides providing radiant as well as direct heat for cooking. Uniquely, due to its very thick cooking stones Alsace can cook for up to two hours after the fire goes out. An added health factor is the fact 95% of the smoke travels up through the air space to the chimney, avoiding the overly smoked flavor of many ovens.

The Alsace also has an optional adjustable warming box on the Right side with 3 removable stainless steel shelves (You can order it). The warming box can be used to keep prepared foods hot while you're cooking other courses or warming bread. The Left side and the right side of the Oven/Grill unit have a convenient cook's work station shelf with towel bar.

Following the Starting the Fire instructions in this manual Alsace will be ready to grill in 20 minutes or less, and within 30-40 minutes the stones will be the perfect temperature to bake in the oven.

To use the grill, pull out the safety knob and tilt the oven up until the safety knob clicks into its top position, exposing the heavy duty stainless steel grill grate. Now you're ready to grill steaks, chops and vegetables, or roast directly over the wood fire.

Planking, roasting, baking, grilling – the cooking possibilities are endless using the patented Alsace dual Oven/Grill combination from L'Art du Jardin.

Distributed by : Longview Products, Canton GA



## Starting the fire

It will take approximately 15-20 minutes for Alsace to reach grilling temperatures and 30-45 minutes to reach baking temperatures. We suggest you use a remote infrared thermometer to measure the temperature of the baking stones surface. The built in door thermometers measure the air temperature inside the oven for traditional oven baking.

### 1°) Choose the right fuel :

Only use fuels that do not produce noxious fumes. For best results we recommend hardwood (12 inches by 4) or chunk charcoal. Do not use timber that has a high resin content such as pine or any treated or painted wood.

### 2°) Fire starters :

Avoid using fire starters such paper or cardboard, it will produce excessive amount of debris. Use kindling or fire starters designed for grills. Open the fire chamber door and place the fire starters on the fire grate.

### 3°) Place the fuel in the fire grate :

Use the right fuel as described in point 1. Do not over-charge. Four chunks will be enough to start.

### 4°) Set the vent knob :

When starting the fire open the air vent all the way, adjust the burn rate and temperature by adjusting the vent during cooking. Do not exceed a temperature of over 500°F/260°C on the built in thermometer. If so, close a bit the vent knob. Do not cook, grill or bake when the flames are excessively high- it is best to wait until the flames have died down and the hot coals are providing the heat source. The double walls of Alsace provide enough heat to cook even after the fire going out.

## Cooking

### 1°) Baking :

When the Alsace is in the oven position the chef can prepare any dish that can be prepared in a traditional oven - with the added flavor of a true wood fired oven. Alsace cooking is a social occasion : cooking for family and friends in the garden is a fun social gathering.

### 2°) Grilling :

By pulling out the safety pin and positioning it in the top grilling position Alsace is ready to cook steaks, roasts, hamburgers, sausages, corn, fish and vegetables - with the advantage and added flavor of using a true wood fire. **WHEN GRILLING MAKE SURE THE FLAME LEVEL IS NOT DANGEROUSLY HIGH BEFORE TILTING THE OVEN UP**

Distributed by : Longview Products, Canton GA



# Maintenance

**1°) ALLOW THE ALSACE OVEN TO COMPLETELY COOL BEFORE PERFORMING MAINTENANCE.**

**2°) «Always use a fire proof container for all ashes and coals when cleaning the oven. Do not dump ashes and coals where they could cause a fire.»**

3°) Empty the fire box residue into a fire proof container.

4°) Empty the ash tray into the fire proof container.

5°) Sweep or vacuum with appropriate steel bbq vacuum cleaner any ashes out of the firebox area.

6°) Remove the cooking stones - DO NOT USE DETERGENTS OR SOAPS TO CLEAN THE STONES.

7°) Clean the inside of the oven using a warm soapy water and non-abrasive scrubber if needed.

8°) Clean the cooking stones by scraping with a non-abrasive plastic scrapper or brush. Hot water can be used to remove grease and oils. DO NOT PUT WET STONES BACK IN THE OVEN - WET STONES CAN CRACK VOIDING THE OVEN'S WARRANTY.

9°) Cleaning the grill : Always clean as you go. That will mean an easier and less time consuming clean in the end. It is best to scrub the grill with a metal grill brush before and after cooking while the grate is still piping hot. When the grill is cold, it should then be oiled to preserve its life. Do this by dipping a paper towel in oil, then using BBQ tongs to run the oil along the grate.

10°) Cleaning the outside of the oven : Wipe the outside of the Alsace oven with a wet rag and some gentle cleaning soap. Be careful not to use a wire brush as you don't want to scratch off any paint.

11°) Storage : Make sure the Alsace is cool to the touch and has been cleaned; using the cover supplied with the oven store it in a protected space.

**PROPER MAINTENANCE AND CLEANING WILL PROLONG THE LIFE OF YOUR ALSACE OVEN,  
PROVIDING MANY YEARS OF GREAT FOOD AND FUN FOR THE ENTIRE FAMILY.**

Distributed by : Longview Products, Canton GA





## Warranty information

**The Alsace Wood fired multifunction Oven and Grill is covered by a 10 years limited warranty from the date of purchase by the original owner. This warranty covers parts and workmanship, it is the sole decision of the seller to either replace any defective parts or replace the entire oven. Parts are supplied free of charge but replacing them is the responsibility of the owner.**

### Conditions :

- Proof of purchase and must be supplied with all claims.
- The oven MUST have been properly used and maintained by the buyer.
- Commercial use voids all warranties.
- Any unauthorized changes, additions, or modifications to the oven void the warranty.
- Supplied repair parts do not extend the warranty.

### Excluded :

- Surface rust or damage caused by abuse or neglect, or surface scratches.
- Glass and stone breakage due to misuse or overheating (Do not exceed a temperature of over 500°F/260°C on the built in thermometer).
- Normal wear and tear.
- Damages caused by abuse, misuse, neglect, lack of maintenance, accidental or improper installation or assembly.
- Scratches, dents, corrosion or discoloration caused by heat, abrasive cleaners, chemical cleaners or chipping.
- This warranty does not cover transportation costs or in home repair charges.

Distributed by : Longview Products, Canton GA

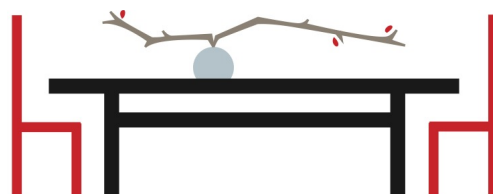

L'ART DU JARDIN

# Warranty form

Please record and send the following information to confirm your warranty.

Date of Purchase : .....

Place of purchase : .....

Location : .....

Invoice number (Copie of the invoice must be joined to this form) : .....

Your name : .....

Your Location : .....

Your Tel : ..... Your mail : .....

Please complete the Warranty Form and forward to Longview Products LLC via :

Email : [customerservice@longviewproducts.com](mailto:customerservice@longviewproducts.com) or

Fax to : 770-591-3293 or

Mail to : Longview Products LLC, Unit 229 3760 Sixes RD, Suite 126 Canton GA 30114 USA

# Accessories

All L'Art du Jardin ovens include an aluminium Pizza peel and an all weather oven cover

Pizza Peel



All weather cover

Distributed by : Longview Products, Canton GA

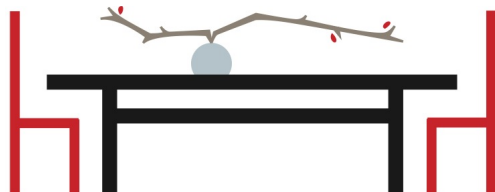

L'ART DU JARDIN



# ALSACE V3

## Assembly Manual

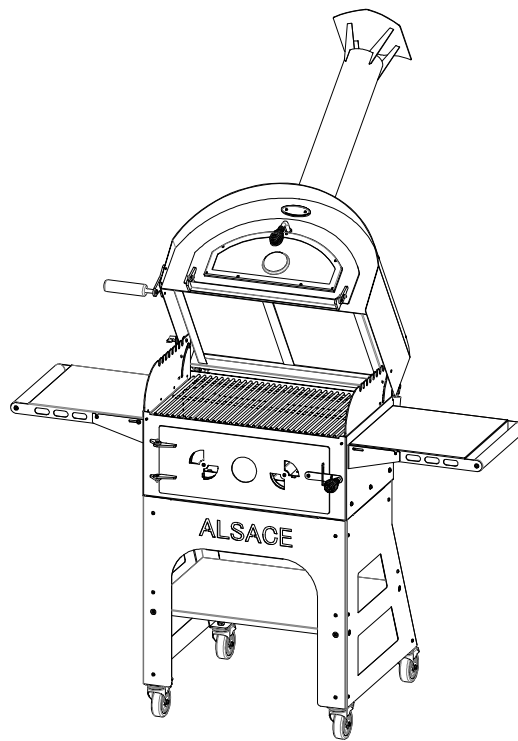

DISTRIBUTED BY :

LONGVIEW PRODUCTS LLC

#229 3760 SIXES ROAD, SUITE 126

CANTON, GA 30114

770-517-3527 [WWW.LONGVIEWPRODUCTS.COM](http://WWW.LONGVIEWPRODUCTS.COM)

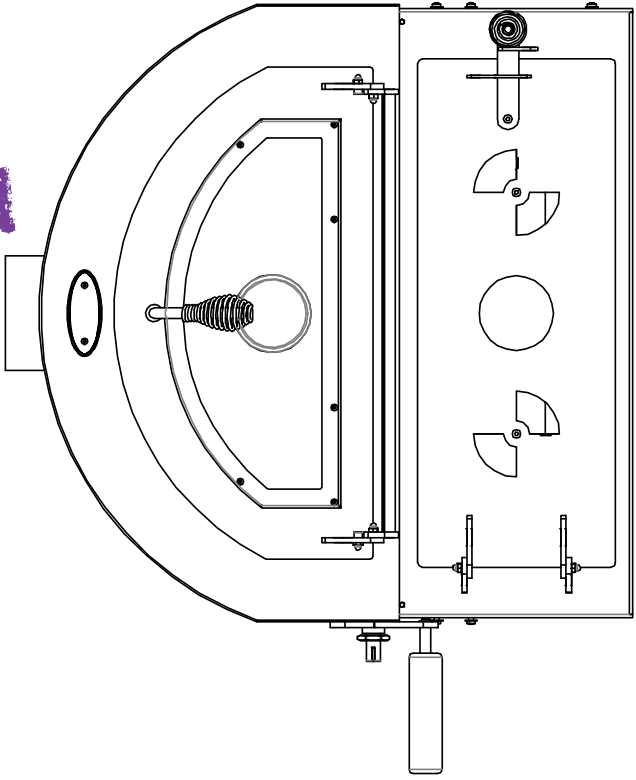

**Remove the oven from the box and remove the ash tray, the fire box and carefully remove the cooking stones, they are fragile.**

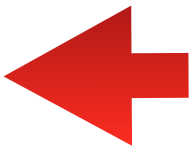

**Step 1**

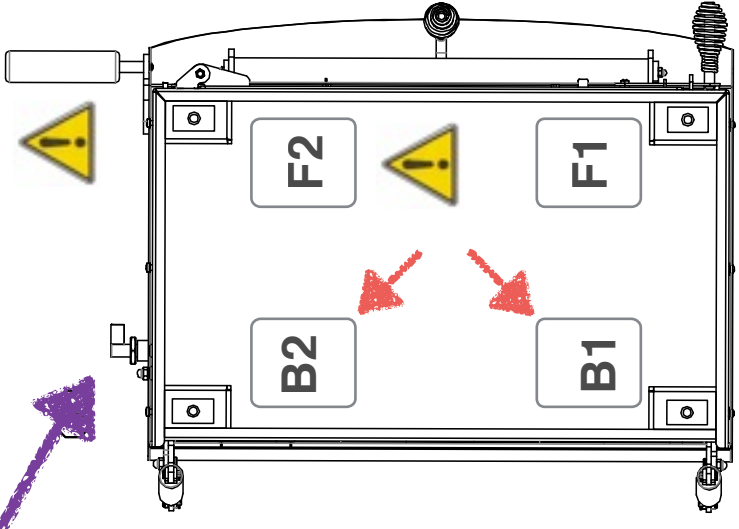

**Styrofoam from packing**

**Remove one of the Styrofoam blocks from the box and lay it on the ground. Carefully lay the oven on the Styrofoam as shown on the diagram.**



**Step 2**





The front wheels lock to prevent movement during cooking. Make sure they are inserted into the front legs as shown on the diagram.



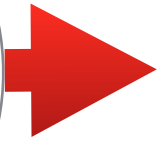

**NOTE : IT IS CRITICAL THAT THE LEGS AND WHEELS ARE IN THE CORRECT POSITIONS. THE FRONT LEGS ARE STRAIGHT AND HAVE LOCKING WHEELS, THE REAR LEGS HAVE A SLIGHT ANGLE AND THE WHEELS DO NOT LOCK.**

**Step 3**

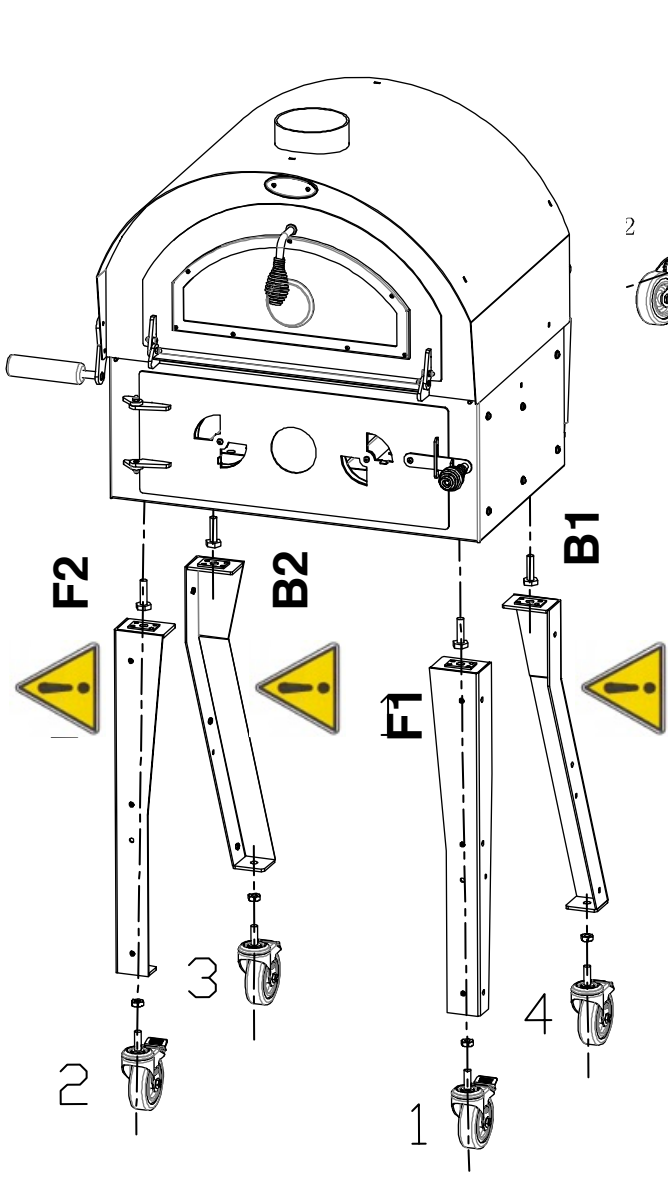

After the wheels are attached to the legs, loosely bolt the legs to the oven. Watch : F1 and F2 at front, B1 and B2 at rear



-  M12\*45 4PCS
-  M12 4PCS
-  N° 1 and 2 Auto-lock at FRONT
-  N° 3 and 4 at



Use the included tools for tightening bolts

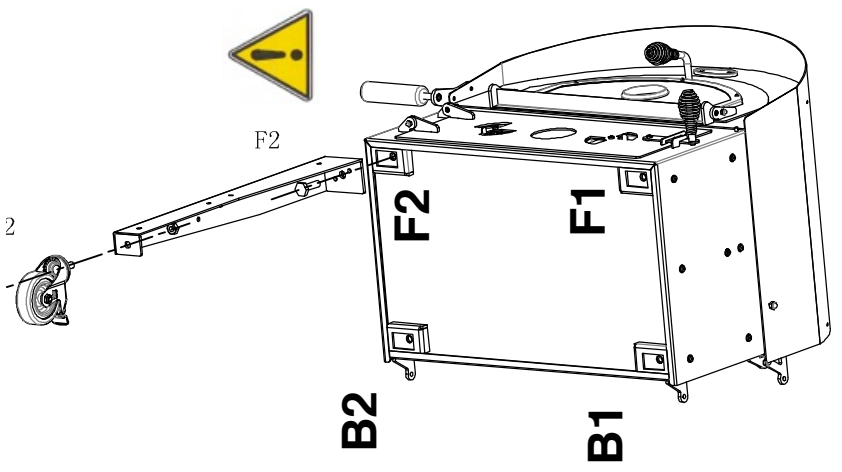

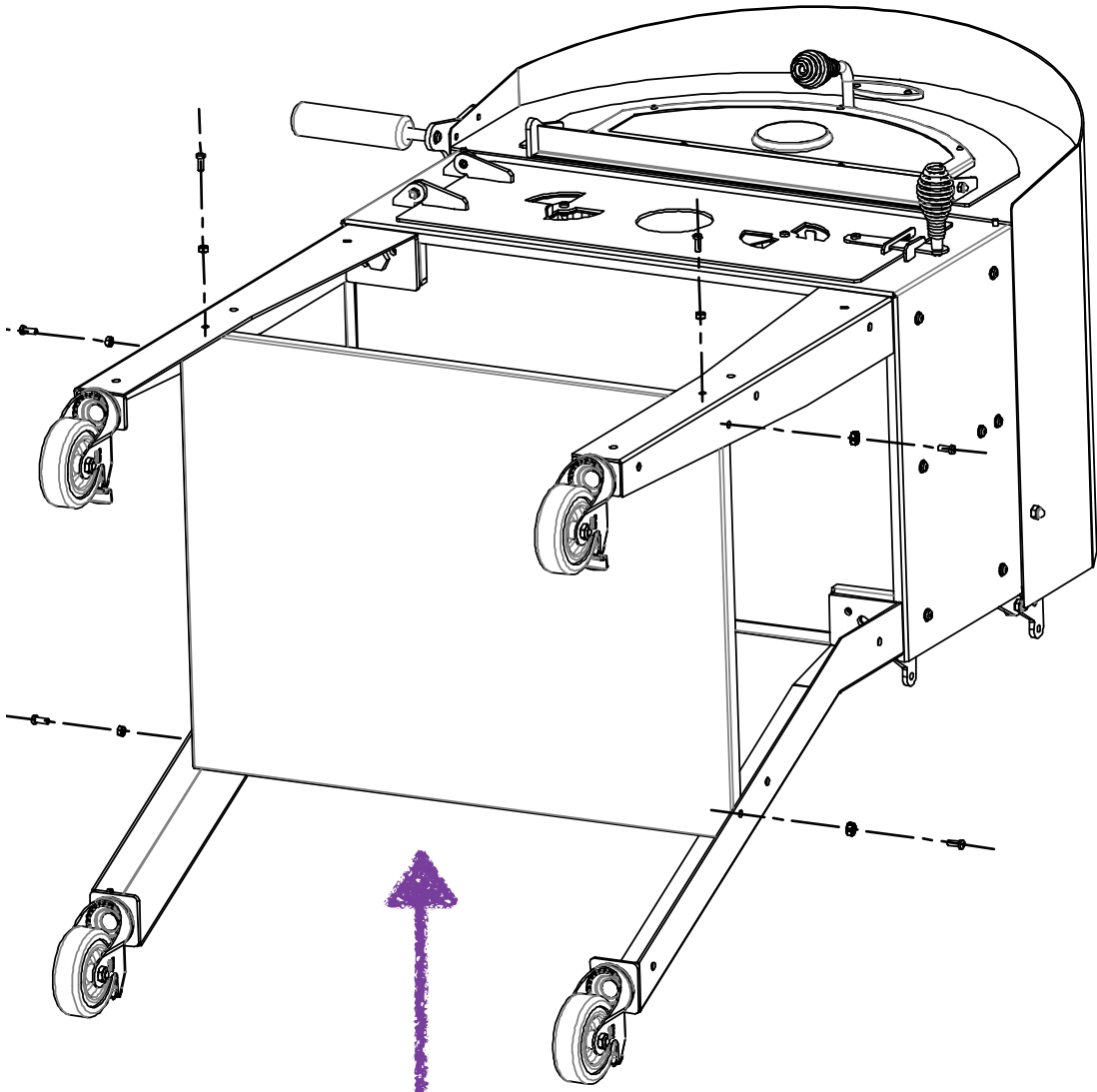

**Do not tighten legs bolts yet**

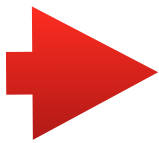

**Step 4**



Using the bolts and nuts provided attach the storage shelf . Now tight firmly the bolts holding the oven to the legs.

-  M6\*16 24PCS
-  M6 6PCS

**Before Step 5, please verify that legs bolts are completely tighten**

Step 5



Attach the sides and front covers to the legs as shown in the diagram.

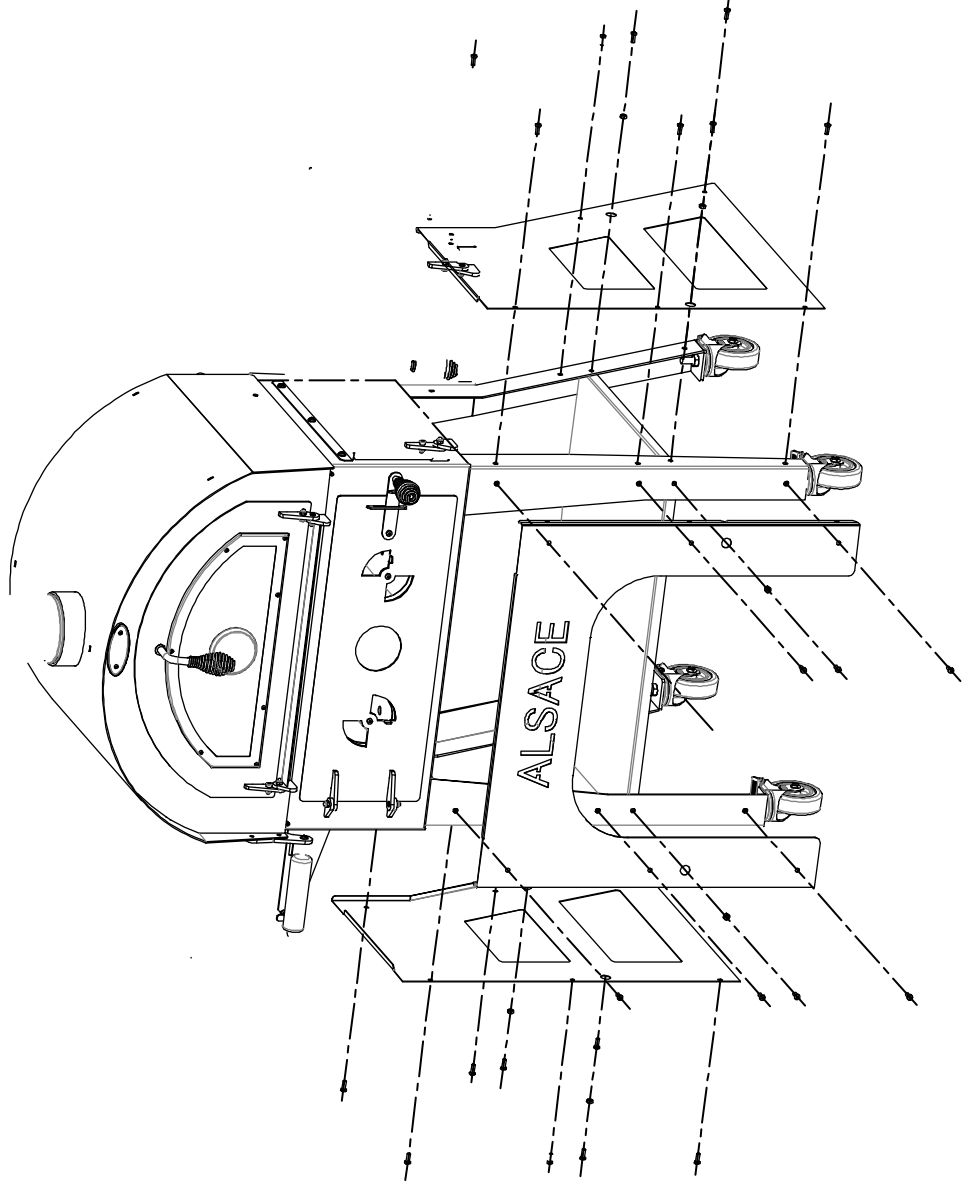

M6\*16 24PCS



M6 6PCS



Now you can stand the oven upright. Note : the oven is very heavy, we suggest that at least two people to be used to bring the oven to an upright position.

## Step 6

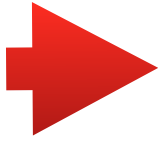

Using the parts provided attach the two pistons to the back of the oven. Make sure the piston rod is on the top.

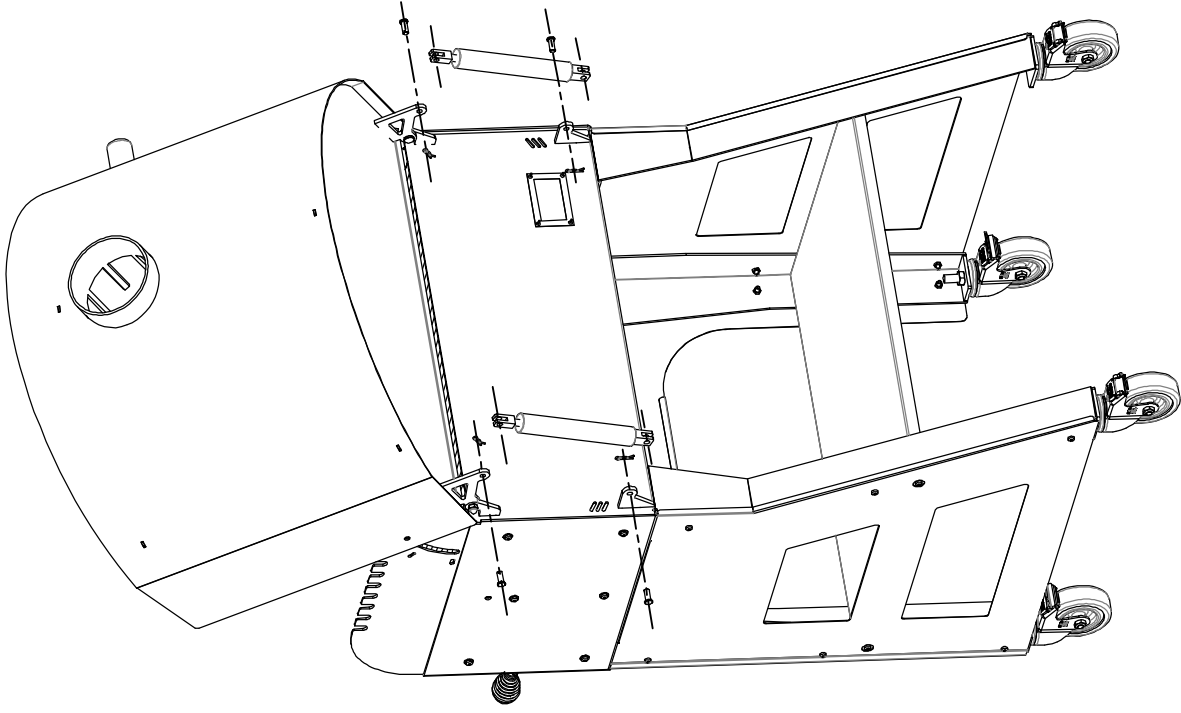

4PCS



4PCS



2PCS





**Step 8**

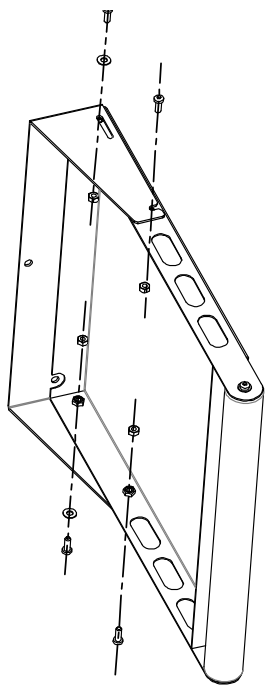

Attach the chimney and chimney cap as shown.



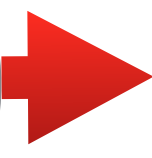

-  M6\*16 8PCS
-  Ø 6 4PCS
-  M6 8PCS

**Step 7**



Assemble the folding side shelves as shown and attach to the sides of the oven. Attach the black lifting handle on the front left as shown.

-  M6\*16 6PCS
-  Ø 6 7PCS
-  M6\*10 1PCS

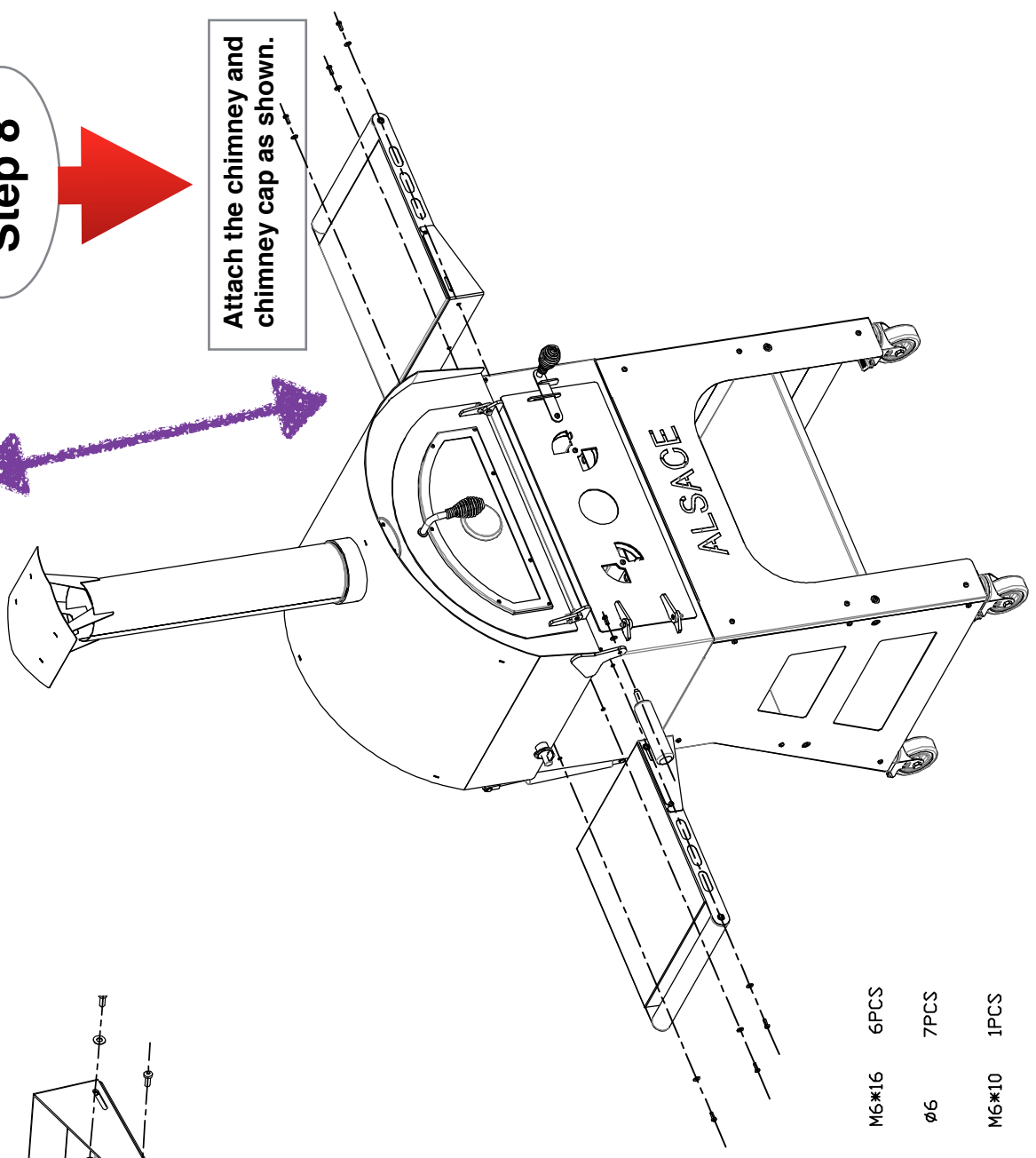

**Step 9**

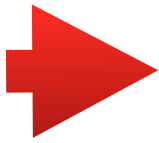

Insert the Ash tray  
and Fire box as  
shown in the  
diagram.

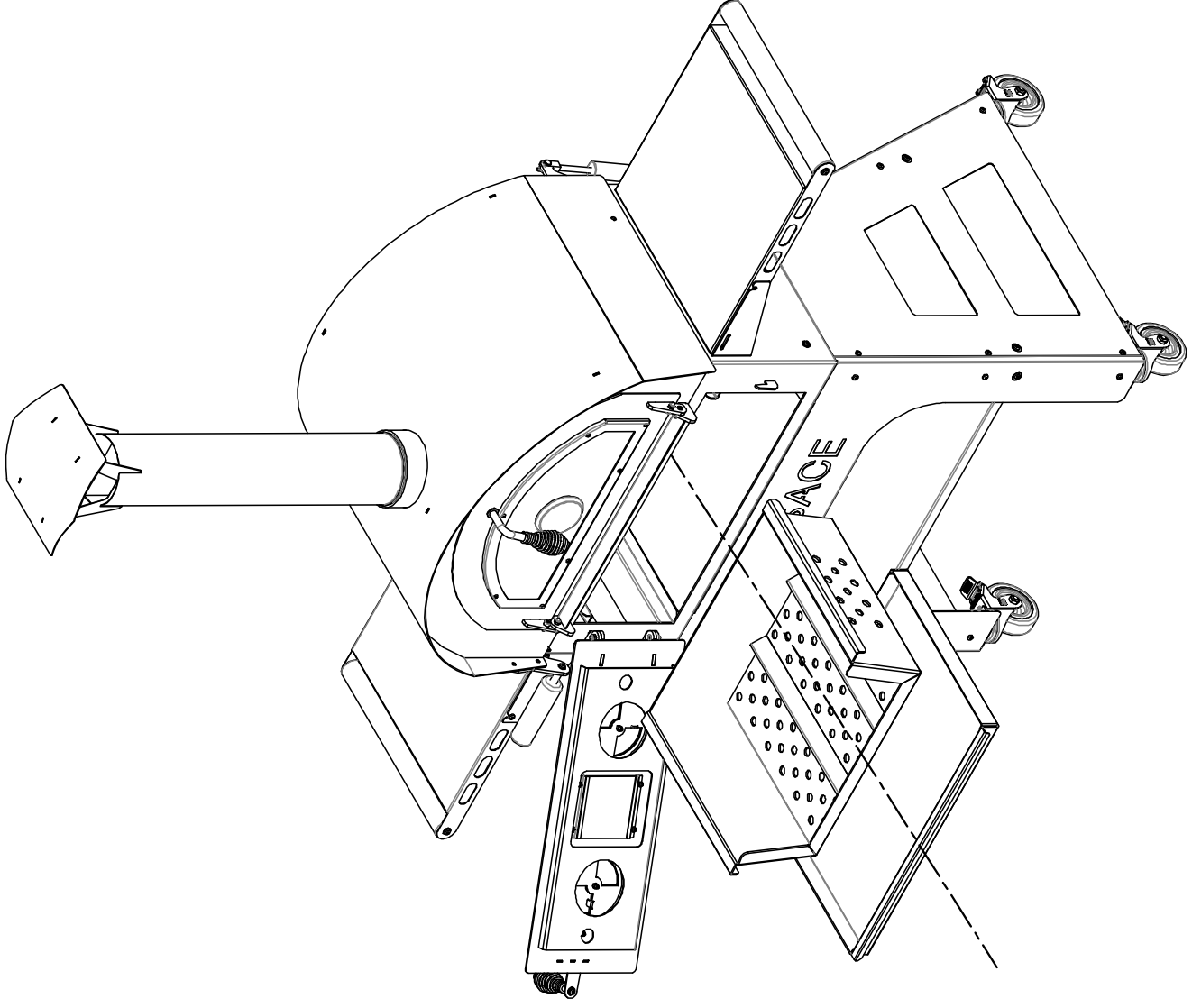

## Step 10



### Safety pin

While pulling out the safety pin catch on the left side of the oven, raise the oven up to the grilling position using the lifting handle.

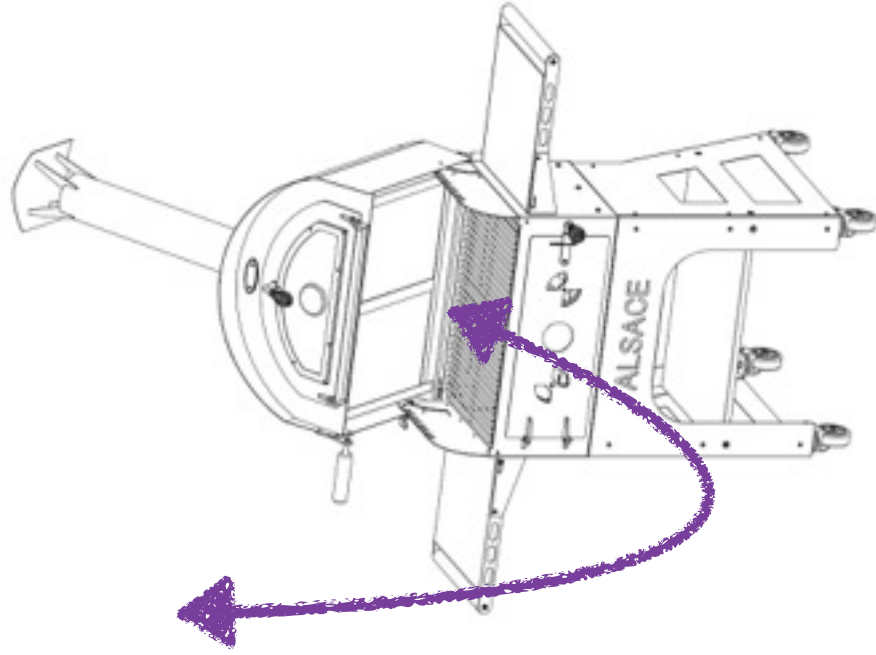

## Step 11

Pulling out the safety pin catch lower back down to the baking position. Open the oven door carefully insert the two cooking stones. The stones are heavy but fragile, always take care when inserting or removing them from the oven.

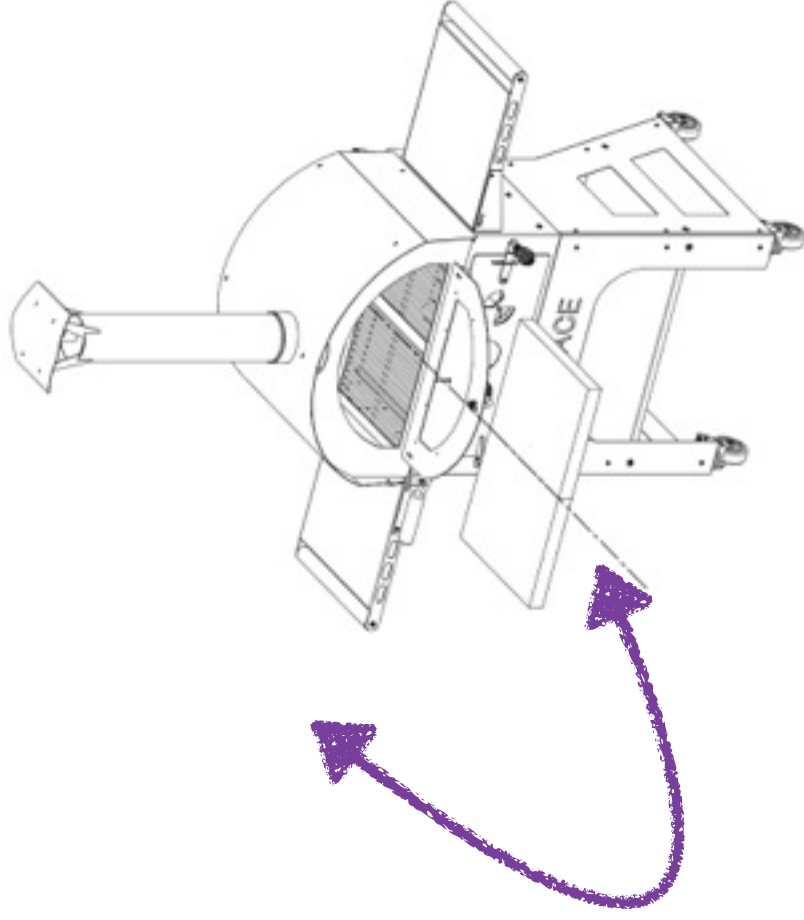

**Step 12**

**Enjoy your L'Art du Jardin Alsace outdoor wood fired oven**



**Your GRILL**

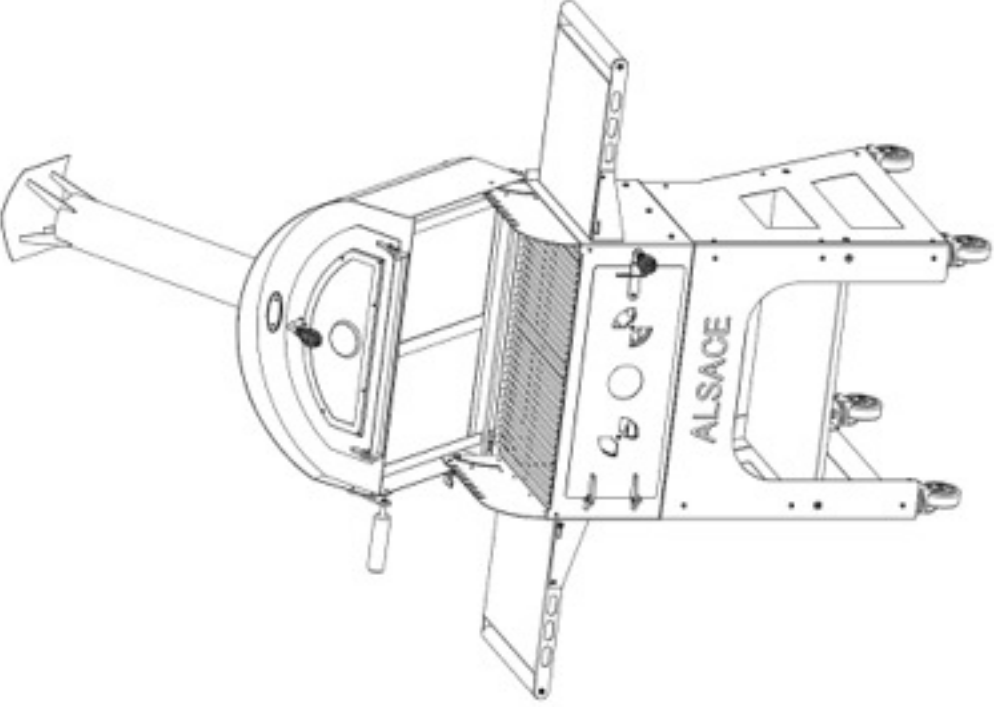

**Your OVEN**

