

## ASSEMBLY INSTRUCTIONS

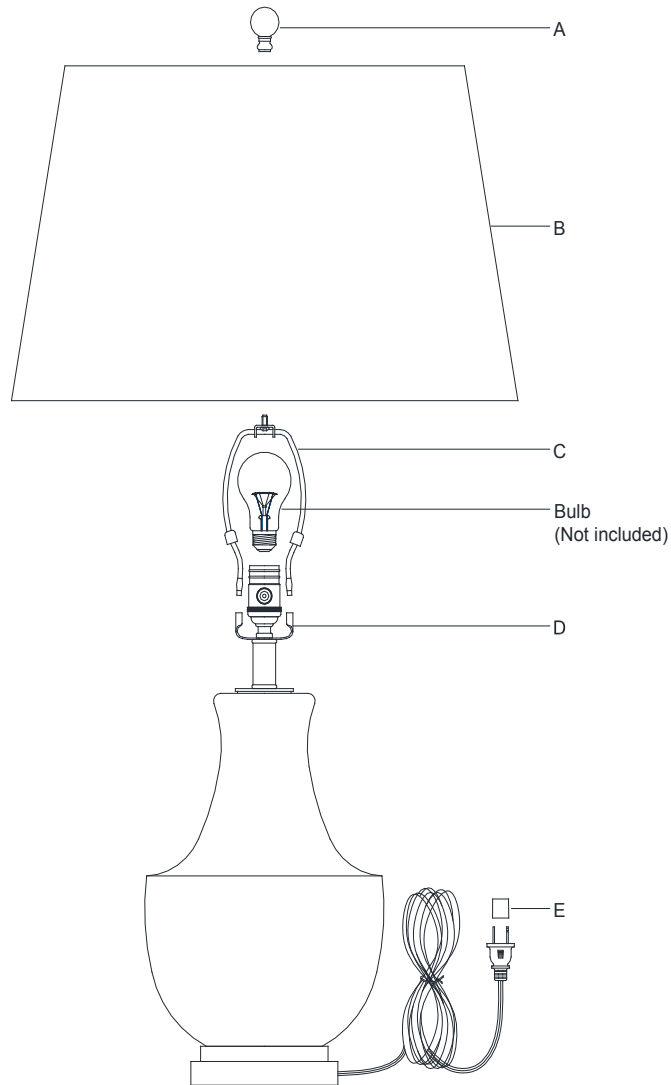

## Marlowe Ceramic Table Lamp Item # CHA 8642

WE RECOMMEND INSTALLATION OF THIS LIGHTING FIXTURE BE DONE BY A LICENSED ELECTRICIAN.

WARNING\*\*\*SWITCH OFF THE MAIN ELECTRICAL SUPPLY FROM THE MAIN FUSE BOX/CIRCUIT BREAKER BEFORE INSTALLATION.

INSPECT ITEM CAREFULLY BEFORE ATTEMPTING TO INSTALL. IF THERE IS ANY DAMAGE OR OBVIOUS DEFECT. DO NOT INSTALL.

ITEM MAY NOT BE RETURNED ONCE IT HAS BEEN INSTALLED.

NOTE: CAREFULLY UNPACK EACH PIECE IN TOP LAYER OF PACKING PRIOR TO REMOVING. RETAIN ALL PACKING MATERIAL UNTIL INSPECTION AND INSTALLATION ARE FINAL.

1. Carefully remove all parts from the box.
2. Install harp (C) onto the saddle (D).
3. Place shade (B) to the harp (C) and secure with finial (A).
4. Insert bulb (not included) into the socket.
5. Remove protective plug cover (E) from the plug.
6. Plug into a proper electrical outlet and test the fixture.
7. Installation is complete.

\*\*\*Clean with a dry, soft cloth only. Use no harsh abrasives or chemical agents.

