

1. Get the Nest app

Before you install your Nest Protect on the ceiling or wall, set it up with the Nest app. Download the app from the Apple App Store™ or Google Play™ and create a free Nest Account. You can use a phone or tablet for setup.



Important: If you already have the Nest app installed on your smartphone or tablet, make sure it's the latest version before setting up your Nest Protect.

2. Set up Nest Protect

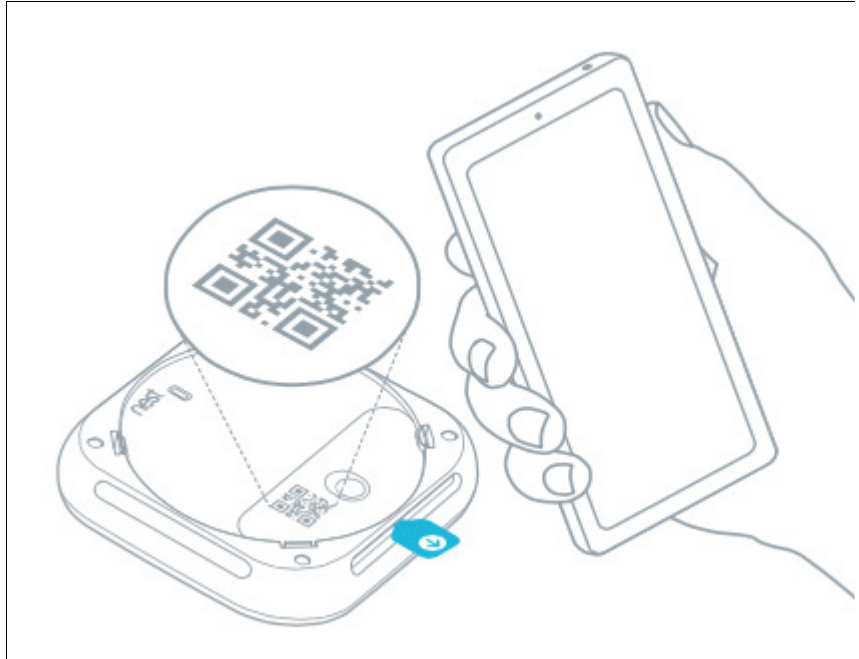

The Nest app will guide you through each step: scanning the Nest Protect QR code, connecting it to the Internet, and connecting it to other Nest Protects in your home.

Tip: Lay everything out on a table for easy setup.

3. Have more Nest Protects?

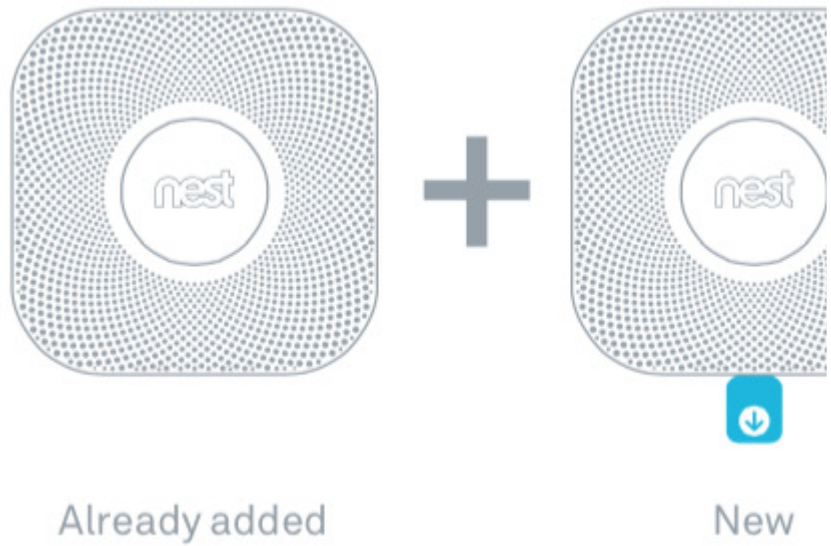

The Nest app will ask you if you have additional Nest Protects to set up. If so, it'll take you through a faster setup. Be sure to keep all your Nest Protects together until they're all set up and ready to be installed.

Tip: Your Nest Protect came packed in a clear plastic dust cover. Keep the cover on so your Nest Protect stays clean until you install it.

4. Remove your old smoke alarm

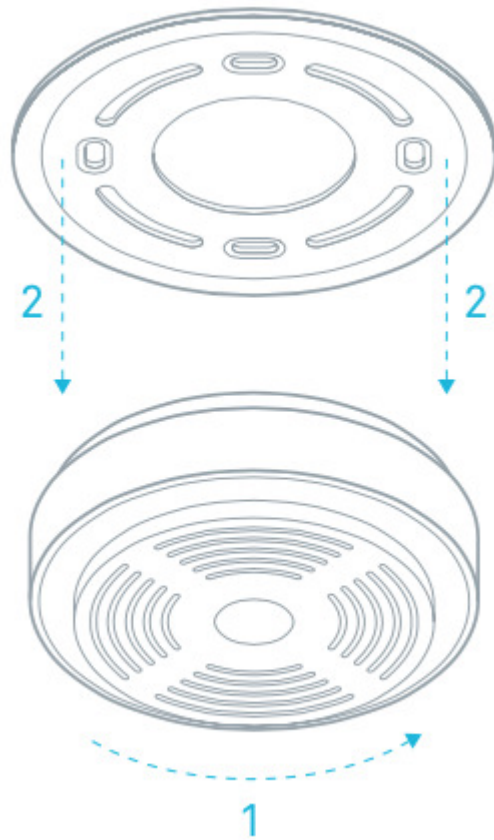

You may have to twist the alarm to release it. Carefully remove it to keep from damaging your ceiling or wall. Unscrew and remove the backplate if there is one.

Tip: Your old smoke alarm might make a loud noise when you disconnect it.

5. Install your Nest Protect backplate

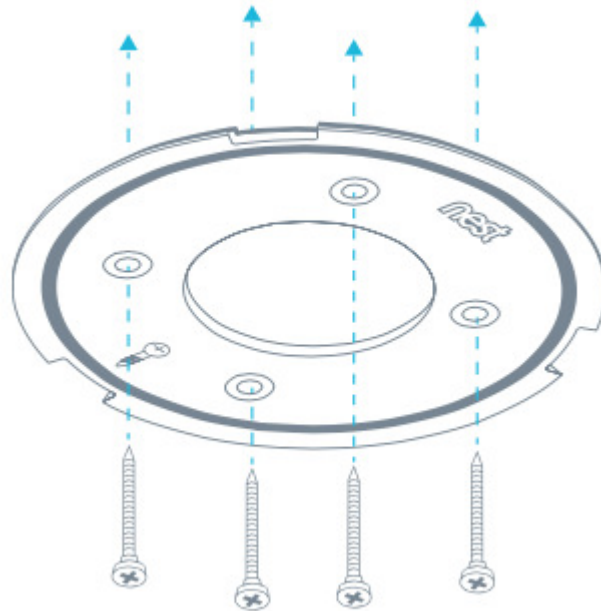

Screw the Nest backplate to the ceiling or wall using the included screws.

Tip: All smoke alarms prefer to live in a dust free area, so remove any dust before you install Nest Protect.

6. Install your Nest Protect

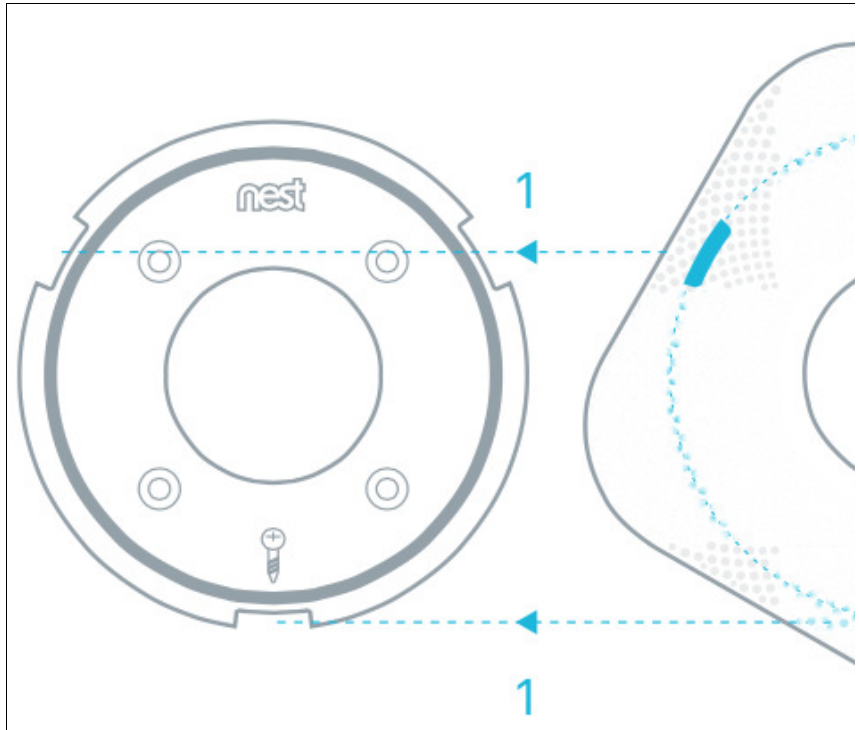

Line up the three tabs on the back of your Nest Protect with the notches on the backplate. Hold Nest Protect against the backplate and turn it clockwise. Continue turning until it's square with the wall or ceiling. Install the rest of your Nest Protects if you have more.

Tip: To remove your Nest Protect (for cleaning or battery replacement), turn it counterclockwise until it disconnects from the backplate.

7. Press to test

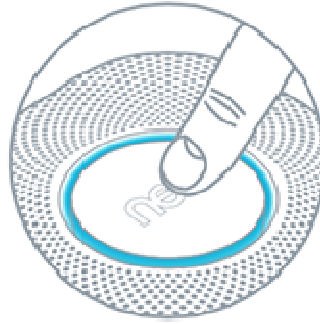

Press the Nest button on one Nest Protect. It will tell you what to do next. Every Nest Protect in the house should speak up, confirming that they're connected to each other.

Important note: If one of your Nest Protects doesn't speak up or sound its alarm during the test, try moving it closer to your other Nest Protects and testing again. It should be located within 50 feet of another Nest Protect, but its range may be affected by your home's construction or interference from other wireless electronics.

If it still doesn't speak up during the test, reset it to defaults and add it to your Nest Account again.

