

NEW MASON GLASS DESK

Important Safety Instructions:

- Please read all instructions carefully before assembling.
- For your safety, assembly by two or more adults is strongly recommended.
- Keep instructions for future use.
- Use only vendor supplied hardware to assemble. Using unauthorized hardware could jeopardize the structural integrity of the item.

Pre-assembly:

- Remove all parts and hardware from the box and lay out on a clear carpeted or scratch-free work surface, as this will avoid damaging parts during assembly. The shipping box provides an ideal work surface.
- Do not dispose of any packaging or contents of the shipping carton until assembly is completed to avoid accidentally discarding small parts or hardware.
- Use the parts and hardware lists below to identify and separate each of the pieces included.
- The illustrations provided allow for easier assembly when used in conjunction with the assembly instructions.
- The use of power tools to aid in assembly is not recommended. Power tools can damage hardware and split wood.

Parts Included:

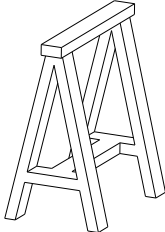
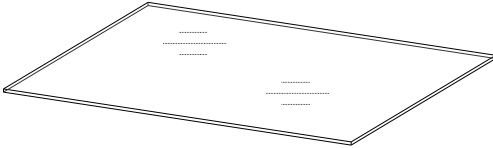
Parts Included (Box 1 of 2):	Parts Included (Box 2 of 2):
<p>(A) Leg</p>  <p>2x</p>	<p>(B) Glass Top</p>  <p>1x</p>

Hardware Included:

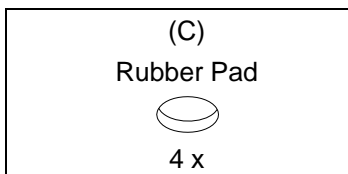

Assembly Instruction Steps:

1. Attach the Rubber Pad (C) to the top rail of Leg (A) as shown. Repeat the step for another leg.

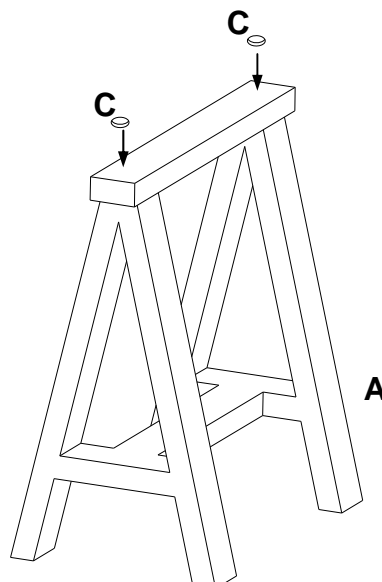

2. Align two legs as shown. Carefully lift up the Glass Top (A) and put it onto the Leg.

WARNING: The legs must be 50 inches apart from each other, as measured from the center of each leg as shown. The Glass desktop must be centered width wise and depth wise.

Assembly is complete!

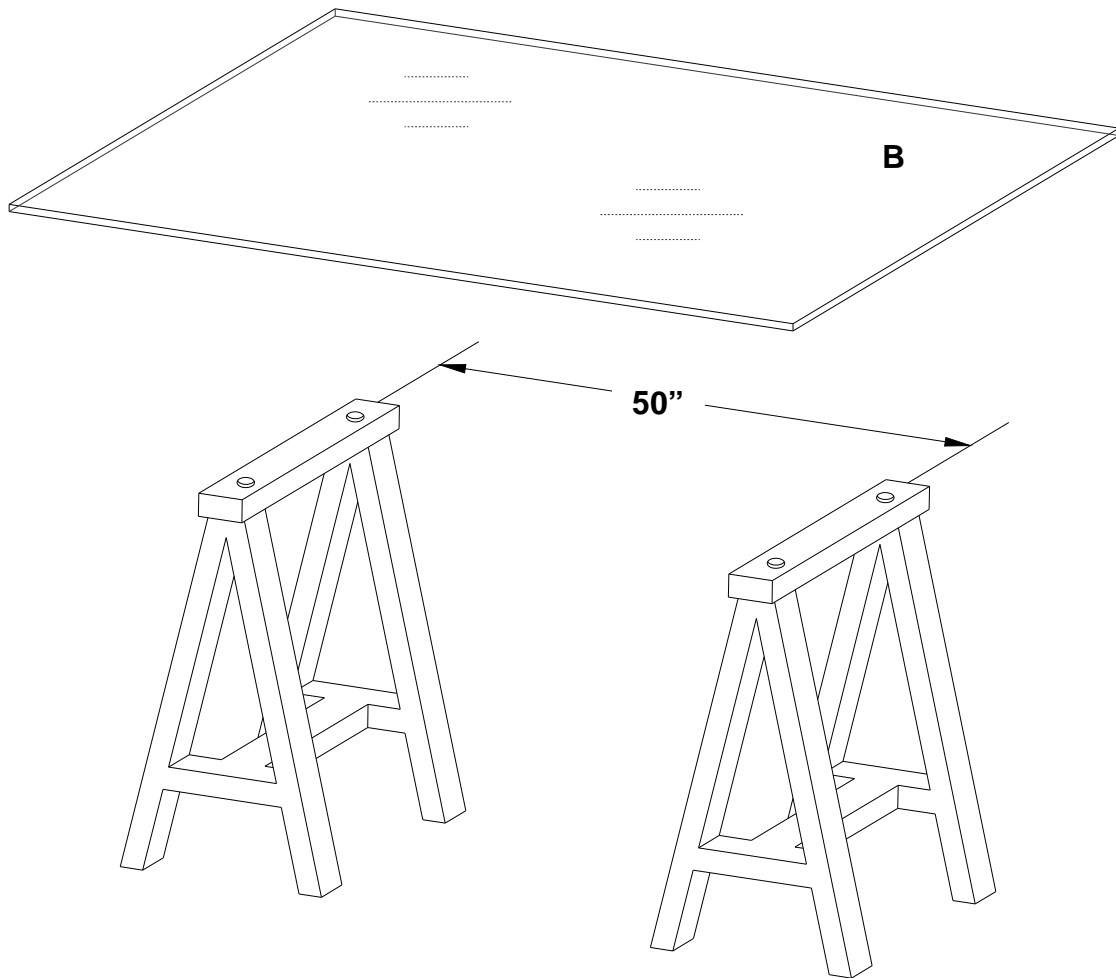

Care Instructions:

- Dust often using a clean, soft, dry and lint-free cloth.
- Blot spills immediately and wipe with a clean, damp, cloth.
- We do not recommend the use of chemical cleansers, abrasives or furniture polish on our lacquered finish.
- For glass tops and shelves, glass cleaner may be used, but avoid spraying it onto the metal or ceramic frame.

Thank you for your purchase
Stores | catalog